

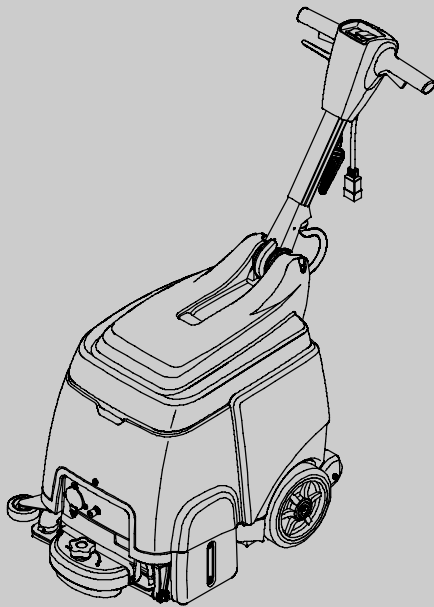

# R3

Carpet Cleaner  
(S/N 6000000-7000000)

## Parts Manual



Models  
9004192-120V  
9004199-230V



*More than clean, it's ReadySpace.™*

North America / International / Japan

[www.tennantco.com](http://www.tennantco.com)

9003733  
Rev. 03 (07-2010)



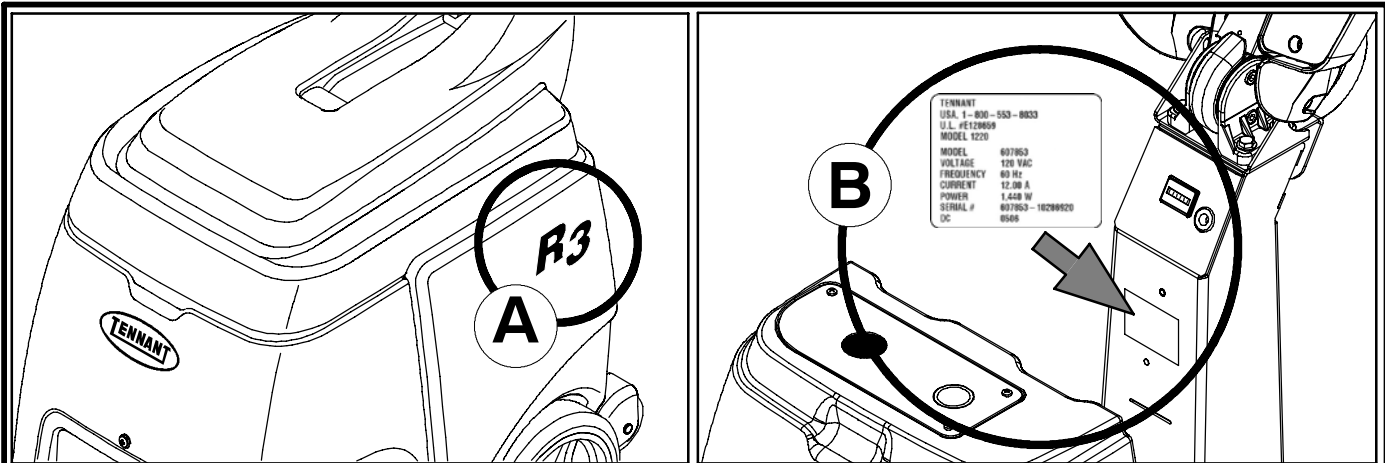

Ref	Part No.	Serial Number	Description	Qty.
1	82681	(000000- )	Bracket W/dt, Lpg Mount	1
2	63810	(000000- )	Ch Assy, Lpg Tank Mtg, W/Nut	4
3	51839	(000000- )	at Adjustable, Lpg Tank Mtg	2
4	49263	(000000- )	Tie, Cable	3
	82556	(000000-001039)	Bracket, Vaporizer	1
	54930	(000000- )	Vaporizer, LPG	1

#### HOW TO ORDER PARTS - See diagram above

Only use TENNANT Company supplied or equivalent parts. Parts and supplies may be ordered online, by phone, by fax or by mail.

Follow the steps below to ensure prompt delivery.

1. (A) Identify the machine model.
2. (B) Identify the machine serial number from the data label.
3. (C) Ensure the proper serial number is used from the parts list.
4. Identify the part number and quantity.  
Do not order by page or reference numbers.
5. Provide your name, company name, customer ID number, billing and shipping address, phone number and purchase order number.
6. Provide detail shipping instructions.

- (D) ▽ - identifies an assembly  
 ▲ - identifies parts included in assembly  
 (E) ● - identifies a recommended stock item

#### Please fill out at time of installation for future reference.

Model No. - \_\_\_\_\_  
 Serial No. - \_\_\_\_\_  
 Machine Options - \_\_\_\_\_  
 Sales Rep. - \_\_\_\_\_  
 Sales Rep. phone no. - \_\_\_\_\_  
 Customer ID Number - \_\_\_\_\_  
 Installation Date - \_\_\_\_\_

#### Tennant Company

PO Box 1452  
 Minneapolis, MN 55440  
 Phone: (800) 553-8033 or (763) 513-2850

www.tennantco.com

Specifications and parts are subject to change without notice.

Copyright © 2008, 2009, 2010 TENNANT Company, Printed in China.

<b>BG</b>	<p><b>КАК ДА ПОРЪЧВАМЕ ЧАСТИ - Вижте схемата по-горе</b></p> <p>Използвайте само части, доставени от TENNANT или техни еквиваленти. Частите и доставките могат да се поръчат онлайн, по телефон, факс или по пощата.</p> <p>Следвайте долупосочените стъпки, за да си осигурите бърза и точна доставка.</p> <ol style="list-style-type: none"> <li><b>(A)</b> Посочете модела на машината.</li> <li><b>(B)</b> Посочете серийния номер на машината от табелката с техническите данни.</li> <li><b>(C)</b> Уверете се, че сте използвали точния сериен номер от списъка с части.</li> <li>Посочва номера на частта и количеството. Не поръчвайте части според страницата или референтните номера.</li> <li>Посочете своето име, наименованието на фирмата, клиентския номер, адреса за получаване на сметката и доставката, тел.номер и номера на поръчката.</li> <li>Посочете подробни инструкции за доставката.</li> </ol> <hr/> <p><b>(D)</b> ▽ - посочва начин на монтаж  <b>(E)</b> ▲ - посочва частите, включени в монтажа  <b>(E)</b> ● - посочва препоръчителен артикул</p>	<p><b>Моля, попълнете по време на монтажа за бъдеща справка.</b></p> <p>Модел Э - _____</p> <p>Сериен Э - _____</p> <p>Опции на машината - _____</p> <p>Търговски представител - _____</p> <p>Тел. Э на търг. представител - _____</p> <p>Клиентски Э - _____</p> <p>Дата на монтаж - _____</p>
-----------	--	---

<b>CN</b>	<p><b>如何订购部件 - 参见下表</b></p> <p>仅使用 TENNANT 公司提供的或同等部件。部件和供应可以在线订购，通过电话、传真或邮件订购。</p> <p>请遵循下面的步骤确保及时交付。</p> <ol style="list-style-type: none"> <li><b>(A)</b> 确定机器型号。</li> <li><b>(B)</b> 从数据标签确定机器序列号。</li> <li><b>(C)</b> 确保使用部件列表中的正确序列号。</li> <li>确定部件号和数量。 不要按页面或参考编号订购。</li> <li>提供您的姓名、公司名称、客户 ID 号、付帐和送货地址、电话号码和采购单编号。</li> <li>提供详细的送货说明。</li> </ol> <hr/> <p><b>(D)</b> ▽ - 确定组件  <b>(E)</b> ▲ - 确定组件中包含的组件  <b>(E)</b> ● - 确定建议的库存项</p>	<p><b>请在安装时填写供未来参考。</b></p> <p>型号 - _____</p> <p>序列号 - _____</p> <p>机器选项 - _____</p> <p>销售代表 - _____</p> <p>销售代表电话号码 - _____</p> <p>客户 ID 编号 - _____</p> <p>安装日期 - _____</p>
-----------	---	--

<b>CZ</b>	<p><b>OBJEDNÁVÁNÍ DÍLŮ - Viz schéma výše.</b></p> <p>Používejte pouze díly dodané společností TENNANT Company nebo jim odpovídající. Díly a materiál lze objednat online, telefonem, faxem nebo poštou.</p> <p>Aby bylo zajištěno rychlé dodání, postupujte podle kroků uvedených níže.</p> <ol style="list-style-type: none"> <li><b>(A)</b> Zjistěte model stroje.</li> <li><b>(B)</b> Zjistěte sériové číslo stroje z výrobního štítku.</li> <li><b>(C)</b> Použijte správné sériové číslo ze seznamu dílů.</li> <li>Určete číslo a množství dílů. Neobjednávejte podle stran nebo referenčních čísel.</li> <li>Uveďte jméno, název společnosti, číslo ID zákazníka, fakturační a dodací adresu, telefonní číslo a číslo objednávky.</li> <li>Uveďte podrobné pokyny pro dodání.</li> </ol> <hr/> <p><b>(D)</b> ▽ - označuje sestavu  <b>(E)</b> ▲ - označuje díly v sestavě  <b>(E)</b> ● - označuje doporučené díly do zásoby</p>	<p><b>Vyplňte během sestavování pro budoucí potřebu.</b></p> <p>Číslo modelu - _____</p> <p>Sériové číslo - _____</p> <p>Doplňky zařízení - _____</p> <p>Obchodní zástupce - _____</p> <p>Tel. č. obchodního zástupce - _____</p> <p>Číslo ID zákazníka - _____</p> <p>Datum instalace - _____</p>
-----------	--	--

<b>DE</b>	<p><b>BESTELLEN VON ERSATZTEILEN - Siehe oben stehendes Diagramm.</b></p> <p>Verwenden Sie nur von TENNANT gelieferte oder gleichwertige Ersatzteile. Ersatz- und Verschleißteile können online, telefonisch, per Fax oder per E-Mail bestellt werden.</p> <p>Befolgen Sie für eine umgehende Lieferung die folgenden Schritte.</p> <ol style="list-style-type: none"> <li><b>(A)</b> Geben Sie das Modell der Maschine an.</li> <li><b>(B)</b> Geben Sie die Seriennummer der Maschine an (auf dem Datenaufkleber).</li> <li><b>(C)</b> Achten Sie darauf, dass die richtigen Seriennummer aus der Ersatzteilliste verwendet wird.</li> <li>Geben Sie die Ersatzteilnummer und die Menge an. Bestellen Sie nicht nach Seitenzahl oder Referenznummern.</li> <li>Geben Sie Ihren Namen, den Firmennamen, die Kundennummer, die Rechnungs- und Lieferadresse, die Telefonnummer und die Einkaufsauftragsnummer an.</li> <li>Erteilen Sie genaue Versandanweisungen.</li> </ol> <hr/> <p><b>(D)</b> ▽ - steht für eine Einheit  <b>(E)</b> ▲ - steht für Einzelteile einer Einheit  <b>(E)</b> ● - steht für einen empfohlenen Vorratsartikel</p>	<p><b>Bitte bei der Inbetriebnahme als Referenzangabe ausfüllen.</b></p> <p>Modellnr. - _____</p> <p>Seriennr. - _____</p> <p>Maschinenoptionen - _____</p> <p>Verkäufer - _____</p> <p>Telefonnummer des Verkäufers - _____</p> <p>Kundennummer - _____</p> <p>Installationsdatum - _____</p>
-----------	---	--

<b>DK</b>	<p><b>BESTILLING AF RESERVEDELE - Se ovenstående tabel.</b></p> <p>Brug kun reservedele, der er fremstillet af TENNANT, eller dele af tilsvarende kvalitet. Reservedele og tilbehør kan bestilles online, pr. telefon, pr. fax eller pr. brev.</p> <p>Følg nedenstående trin for at sikre hurtig levering.</p> <ol style="list-style-type: none"> <li>1. <b>(A)</b> Identificér maskinmodellen.</li> <li>2. <b>(B)</b> Identificér maskinens serienummer på datamærkaten.</li> <li>3. <b>(C)</b> Kontrollér, at det rigtige serienummer bruges i reservedelslisten.</li> <li>4. Identificér reservedelsnummeret og antallet. Bestil ikke efter side- eller referencenumre.</li> <li>5. Angiv dit navn, firmanavn, kunde-id-nummer, faktureringsadresse og leveringsadresse, telefonnummer og indkøbsordnummer.</li> <li>6. Angiv detaljerede instruktioner til forsendelse.</li> </ol> <hr/> <p><b>(D)</b> ▽ - identificerer en enhed  <b>(E)</b> ▲ - identificerer reservedele i en enhed  <b>(E)</b> ● - identificerer en anbefalet lagerkomponent</p>	<p><b>Udfyld venligst på installationstidspunktet til fremtidig brug.</b></p> <p>Modelnr. - _____</p> <p>Serienr. - _____</p> <p>Maskinekraudstyr - _____</p> <p>Salgskonsulent. - _____</p> <p>Salgskonsulentens tlf. - _____</p> <p>Kunde-id-nr. - _____</p> <p>Installationsdato - _____</p>
-----------	--	---

<b>EE</b>	<p><b>KUIDAS VARUOSI TELLIDA - Vaadale alltoodud joonist.</b></p> <p>Kasutage ainult TENNANT Company poolt tarnitud või samaväärseid varuosi. Varuosi ja tarvikuid võib tellida Internetist, telefoni, faksi või posti teel.</p> <p>Kiire kohaletoimetamise tagamiseks järgige järgmisi juhiseid.</p> <ol style="list-style-type: none"> <li>1. <b>(A)</b> Märkige masina mudel.</li> <li>2. <b>(B)</b> Märkige andmesildil olev masina seerianumber.</li> <li>3. <b>(C)</b> Veenduge, et olete valinud varuosade loendist õige seerianumbri.</li> <li>4. Märkige varuosade number ja kogus. Ärge tellige lehekülje- või viitenumbri alusel.</li> <li>5. Märkige oma nimi, ettevõtte nimi, kliendinumbr, arve- ja saatmisadress, telefoninumber ja ostutellimuse number.</li> <li>6. Lisage täpsed saatmisjuhised.</li> </ol> <hr/> <p><b>(D)</b> ▽ - tähistab komplekti  <b>(E)</b> ▲ - tähistab komplektis olevaid osi  <b>(E)</b> ● - tähistab soovitatavat laodetaili</p>	<p><b>Palun täitke paigaldamise ajal edaspidiseks viitamiseks.</b></p> <p>Mudeli nr - _____</p> <p>Seerianr - _____</p> <p>Masina valikulised detailid - _____</p> <p>Müügiesindus - _____</p> <p>Müügiesinduse telefoninumber - _____</p> <p>Kliendi number - _____</p> <p>Paigaldamise kuupäev - _____</p>
-----------	---	--

<b>ES</b>	<p><b>CÓMO SOLICITAR PIEZAS - Consulte el diagrama anterior.</b></p> <p>Utilice sólo las piezas suministradas por TENNANT Company o piezas equivalentes. Puede solicitar las piezas a través de internet, por teléfono, por fax o por correo.</p> <p>Siga los siguientes pasos para que la entrega sea rápida.</p> <ol style="list-style-type: none"> <li>1. <b>(A)</b> Indique el modelo de máquina.</li> <li>2. <b>(B)</b> Indique el número de serie de la etiqueta de datos.</li> <li>3. <b>(C)</b> Asegúrese de que indica el número de serie correcto de la lista de piezas.</li> <li>4. Indique la cantidad y el número de la pieza. No realice el pedido indicando el número de página o el de referencia.</li> <li>5. Incluya su nombre, el nombre de la empresa, el ID de cliente, las direcciones de envío y facturación, el número de teléfono y el número del pedido de compra.</li> <li>6. Facilite instrucciones de envío.</li> </ol> <hr/> <p><b>(D)</b> ▽ - identifica un conjunto  <b>(E)</b> ▲ - identifica piezas de un conjunto  <b>(E)</b> ● - identifica un artículo que conviene tener en stock</p>	<p><b>Rellene estos datos cuando realice la instalación para utilizarlos como referencia en el futuro.</b></p> <p>Nº modelo - _____</p> <p>Nº serie - _____</p> <p>Opciones de la máquina - _____</p> <p>Vendedor - _____</p> <p>Nº teléfono vendedor - _____</p> <p>Nº cliente - _____</p> <p>Fecha de instalación - _____</p>
-----------	---	---

<b>FI</b>	<p><b>KUINKA VARAOSIA TILATAAN - katso kuvaa yllä.</b></p> <p>Käytä ainoastaan TENNANTIN toimittamia tai niitä vastaavia varaosia. Voit tilata varaosia ja tarvikkeita internetistä, puhelimitse, faksilla tai sähköpostilla.</p> <p>Noudata seuraavia ohjeita täsmällisen toimituksen varmistamiseksi.</p> <ol style="list-style-type: none"> <li>1. <b>(A)</b> Katso koneen malli.</li> <li>2. <b>(B)</b> Katso koneen sarjanumero sen tunnustarrasta.</li> <li>3. <b>(C)</b> Varmista, että osaluettelosta, että käytät oikeaa sarjanumeroa.</li> <li>4. Katso osanumero ja kappalemäärä. Älä tilaa ilmoittamalla sivu- tai viitenumeroita.</li> <li>5. Ilmoita nimesi, yrityksesi nimi, asiakasnumero, laskutus- ja toimitusosoite, puhelinnumero ja ostotilauksen numero.</li> <li>6. Ilmoita yksityiskohtaiset toimitusosoitteet.</li> </ol> <hr/> <p><b>(D)</b> ▽ - tarkoittaa kokoonpanoa  <b>(E)</b> ▲ - tarkoittaa kokoonpanoon sisältyviä osia  <b>(E)</b> ● - tarkoittaa osaa, joka olisi suositeltavaa tilata varastoon</p>	<p><b>Ole hyvä ja täytä ottaessasi koneen käyttöön myöhempiä tarpeita varten.</b></p> <p>Mallinumero - _____</p> <p>Sarjanumero - _____</p> <p>Koneen lisävarusteet - _____</p> <p>Myyntiedustaja - _____</p> <p>Myyntiedustajan puhelinnumero - _____</p> <p>Asiakasnumero - _____</p> <p>Asennuspäivä - _____</p>
-----------	--	---

<b>FR</b>	<p><b>COMMENT COMMANDER DES PIÈCES DÉTACHÉES - Voir le schéma ci-dessus.</b></p> <p>Utilisez uniquement des pièces fournies par la société TENNANT ou équivalentes. Les pièces et fournitures peuvent être commandées en ligne, par téléphone, fax, ou par courrier.</p> <p>Suivez les étapes ci-dessous pour assurer une livraison rapide.</p> <ol style="list-style-type: none"> <li><b>(A)</b> Identifiez le modèle de la machine.</li> <li><b>(B)</b> Identifiez le numéro de série de la machine, à partir de l'étiquette signalétique.</li> <li><b>(C)</b> Assurez-vous que le numéro de série correct est utilisé à partir de la liste de pièces détachées.</li> <li>Identifiez le numéro de pièce et la quantité. Ne commandez pas par page ou numéros de référence.</li> <li>Fournissez votre nom, le nom de votre société, votre numéro d'identification de client, l'adresse de facturation et d'expédition, le numéro de téléphone et le numéro du bon de commande.</li> <li>Fournissez des instructions d'expédition détaillées.</li> </ol> <hr/> <p><b>(D)</b> ▽ - identifie un assemblage  <b>(E)</b> ▲ - identifie les pièces composant l'assemblage  ● - identifie un article de stock recommandé</p>	<p><b>A remplir au moment de l'installation à titre de référence.</b></p> <p>N° du modèle - _____</p> <p>N° de série - _____</p> <p>Options de la machine - _____</p> <p>Agent commercial - _____</p> <p>N° tél. de l'agent commercial - _____</p> <p>Numéro d'identification client - _____</p> <p>Date d'installation - _____</p>
-----------	--	---

<b>GR</b>	<p><b>ΤΡΟΠΟΣ ΠΑΡΑΓΓΕΛΙΑΣ ΑΝΤΑΛΛΑΚΤΙΚΩΝ - Βλ. παραπάνω διάγραμμα.</b></p> <p>Χρησιμοποιήστε μόνο ανταλλακτικά παρεχόμενα από την TENNANT Company ή ισοδύναμα. Τα ανταλλακτικά και αναλώσιμα μπορούν να παραγγελθούν online, τηλεφωνικά, με φάξ ή ταχυδρομικά.</p> <p>Ακολουθήστε τα παρακάτω βήματα για να εξασφαλίσετε την έγκαιρη αποστολή τους.</p> <ol style="list-style-type: none"> <li><b>(A)</b> Βρείτε το μοντέλο μηχανήματος.</li> <li><b>(B)</b> Βρείτε τον αριθμό σειράς του μηχανήματος από την ετικέτα στοιχείων.</li> <li><b>(C)</b> Βεβαιωθείτε ότι χρησιμοποιείται ο σωστός αριθμός σειράς από τον κατάλογο ανταλλακτικών.</li> <li>Βρείτε κωδικό ανταλλακτικού και ποσότητα. Μην παραγγέλνετε βάσει σελίδας ή αριθμών αναφοράς.</li> <li>Δώστε το όνομα σας, όνομα εταιρείας, ID (κωδικό) πελάτη, διεύθυνση τιμολόγησης και αποστολής, αριθμό τηλεφώνου και αριθμό εντολής προμήθειας.</li> <li>Δώστε λεπτομερείς πληροφορίες αποστολής.</li> </ol> <hr/> <p><b>(D)</b> ▽ - υποδηλώνει υποσύστημα  <b>(E)</b> ▲ - υποδηλώνει τα μέρη που περιλαμβάνονται στο υποσύστημα  ● - υποδηλώνει ένα συνιστώμενο στοιχείο αποθήκης</p>	<p><b>Παρακαλούμε συμπληρώστε κατά την ώρα της εγκατάστασης για μελλοντική αναφορά.</b></p> <p>Αρ. Μοντέλου - _____</p> <p>Αρ. σειράς - _____</p> <p>Επιλογές Μηχανήματος - _____</p> <p>Εκπ. πωλήσεων - _____</p> <p>Τηλ. εκπροσώπου πωλήσεων - _____</p> <p>Αριθμός πελάτη - _____</p> <p>Ημερομηνία εγκατάστασης - _____</p>
-----------	--	---

<b>HU</b>	<p><b>HOGYAN RENDELJÜNK ALKATRÉSZEKET - Lásd: fenti diagramm.</b></p> <p>Kizárólag TENNANT vagy azzal egyenértékű cserealkatrészeket használjon. Az alkatrészeket és anyagokat meg lehet rendelni az Interneten keresztül, vagy telefonon, faxon és e-mailben.</p> <p>A pontos szállítás érdekében kövesse az alábbi lépéseket.</p> <ol style="list-style-type: none"> <li><b>(A)</b> Adja meg a gép típusát.</li> <li><b>(B)</b> Az adatszímke alapján adja meg a gép gyártási számát.</li> <li><b>(C)</b> Ügyeljen arra, hogy a megfelelő gyártási számot válassza ki az alkatrészlistáról.</li> <li>Adja meg a rendelési számot és a mennyiséget. A rendeléshez ne az oldalszámot vagy a hivatkozási számot használja.</li> <li>Adja meg a nevét, a cége nevét, az ügyféazonosító számát, a számlázási és szállítási címét, a telefonszámát és a rendelési számot.</li> <li>Adjon részletes szállítási utasításokat.</li> </ol> <hr/> <p><b>(D)</b> ▽ - a jel csomagra utal  <b>(E)</b> ▲ - a jel a csomagban található alkatrészekre utal  ● - a jel raktárkészleten tartandó cikkekre utal</p>	<p><b>A későbbi visszakeresések érdekében kérjük, hogy a rovatokat az első üzembehelyezéskor töltsé ki.</b></p> <p>Típuszám - _____</p> <p>Gyártási szám - _____</p> <p>A gép felszereltsége - _____</p> <p>Kereskedelmi képviselő - _____</p> <p>Kereskedelmi képviselő telefonszáma - _____</p> <p>Ügyfél azonosító száma - _____</p> <p>Üzembehelyezés dátuma - _____</p>
-----------	---	--

<b>IT</b>	<p><b>COME ORDINARE LE PARTI - Vedere schema precedente.</b></p> <p>Utilizzare solo ricambi forniti da TENNANT o equivalenti. Ricambi e forniture possono essere ordinati online, per telefono, via fax o per posta elettronica.</p> <p>Per ottenere una consegna rapida, seguire i passaggi indicati di seguito.</p> <ol style="list-style-type: none"> <li><b>(A)</b> Identificare il modello della macchina.</li> <li><b>(B)</b> Identificare il numero di serie della macchina dall'etichetta dei dati.</li> <li><b>(C)</b> Utilizzare il numero di serie corretto presente nell'elenco delle parti di ricambio.</li> <li>Identificare numero di parte e quantità. Non ordinare per numero di pagina o di riferimento.</li> <li>Fornire nome del contatto, nome della società, numero di ID cliente, indirizzo di fatturazione e di spedizione, numero di telefono e numero di ordine di acquisto.</li> <li>Fornire istruzioni dettagliate per la spedizione.</li> </ol> <hr/> <p><b>(D)</b> ▽ - identifica un gruppo  <b>(E)</b> ▲ - identifica parti comprese in un gruppo  ● - identifica una parte a scorta consigliata</p>	<p><b>Compilare il modulo al momento dell'installazione per poterlo consultare in futuro in caso di necessità.</b></p> <p>N. Modello - _____</p> <p>N. Serie - _____</p> <p>Opzioni della macchina - _____</p> <p>Venditore - _____</p> <p>Tel. venditore - _____</p> <p>Numero ID cliente - _____</p> <p>Data di installazione - _____</p>
-----------	---	---

<b>JP</b>	<p><b>パーツの発注方法 ? 上記の図を参照してください</b></p> <p>TENNANT社製のパーツまたは同等品のみをお使いください。          パーツやサプライ品のご注文は、オンライン、電話、FAX、または手紙でお願いいたします。          確実にお届けできるように、以下の情報お知らせください。</p> <ol style="list-style-type: none"> <li><b>(A)</b> 製品のモデル名をお知らせください。</li> <li><b>(B)</b> 製品のデータラベルに印刷されているシリアル番号をお知らせください。</li> <li><b>(C)</b> パーツリストを参照して、シリアル番号が正しいかご確認ください。</li> <li>パーツ番号と数量をお知らせください。マニュアル/カタログのページ番号や参照番号でのご注文はご遠慮ください。</li> <li>お客様のお名前、会社名、顧客ID番号、請求/発送先住所、電話番号、注文書番号をお知らせください。</li> <li>発送に関するご希望があれば、明記してください。</li> </ol> <hr/> <p><b>(D)</b> ▽ - アセンブリを示します          ▲ - アセンブリに含まれるパーツを示します  <b>(E)</b> ● - 当社推薦の在庫用品を示します</p>	<p><b>後日確認できるように、設置時に記入してください。</b></p> <p>モデルNo. - _____</p> <p>シリアルNo. - _____</p> <p>製品のオプション - _____</p> <p>販売代理店 - _____</p> <p>販売代理店の電話番号 - _____</p> <p>顧客ID番号 - _____</p> <p>設置日 - _____</p>
-----------	---	---

<b>LT</b>	<p><b>KAIP U SISAKYTI DALIS - r. diagramà vir uje.</b></p> <p>Naudokite tik "Tennant" kompanijos tiekiamas arba lygiavertes joms dalis. Dalis galite u sisakyti internetu, telefonu, faksu bei elektroniniu pa tu.</p> <p>Kad u sakymas būtų greitai ávykdytas, laikykitės i vardyto taisykliu.</p> <ol style="list-style-type: none"> <li><b>(A)</b> Nurodykite ma inos modelà.</li> <li><b>(B)</b> Norodykite ma inos serijos numerà, kurà rasite ant duomenø ymës.</li> <li><b>(C)</b> Ásitikinkite, kad nurodomas tikslus serijos numeris i daliø sàra o.</li> <li>Nurodykite dalies numerà ir reikiamà kiekà.          Neu sakinëkite pagal puslapius ar nuorodos numerius.</li> <li>Nurodykite savo vardà, kompanijos pavadinimà, kliento ID numerà, sàskaitos i ra ymo ir ve imo adresà, telefono numerà ir pirkimo u sàkymo numerà.</li> <li>Nurodykite i samias gabenimo instrukcijas.</li> </ol> <hr/> <p><b>(D)</b> ▽ - ymi sistemà          ▲ - nurodo sistemos dalis  <b>(E)</b> ● - nurodo rekomenduotinà dalà</p>	<p><b>Pra ome u pildyti montavimo metu, siekiant gauti informacijà ateityje.</b></p> <p>Modelio Nr. - _____</p> <p>Serijos Nr. - _____</p> <p>Ma inos versija - _____</p> <p>Komivoja ierius - _____</p> <p>Komivoja ieriaus tel. nr. - _____</p> <p>Pirkëjo ID numeris - _____</p> <p>Sumontavimo data - _____</p>
-----------	--	---

<b>LV</b>	<p><b>KÀ PASÛTÎT REZERVES DETAÏAS - Skat. diagrammu iepriek .</b></p> <p>izmantojiet tikai TENNANT Company piegàdâtàs vai tàm lidzvcrtigas rezerves detaïas. Daïas un piegàdi var pasûtît internetà, pa tãlruni, pa faksu vai pastu.</p> <p>Lai nodro inātu savlaicïgu piegàdi, sekojiet zemàk aprakstïtajiem soïem.</p> <ol style="list-style-type: none"> <li><b>(A)</b> Nosakiet ma ïnas modeli.</li> <li><b>(B)</b> Nosakiet ma ïnas sçrijas numuru uz tehnisko datu uzlïmes.</li> <li><b>(C)</b> Pãrliecinieties, ka tiek uzrakstïts attiecïgais sçrijas numurs no detaïu saraksta.</li> <li>Nosakiet detaïas numuru un skaitu.          Veicot pasûtïjumus neatsaucieties uz lappu u vai norãdes numuriem.</li> <li>Uzrakstiet savu vãrdu, uzdøcnuma nosaukumi, klienta identitãtes numuru, adresi rçïna piesûtï anai un piegãdei un pirkuma pasûtïjuma numuru.</li> <li>Sniedziet detalizçtu informãciju par piegãdi.</li> </ol> <hr/> <p><b>(D)</b> ▽ - nosaka ierici          ▲ - nosaka detaïas, kas ir komplektã ar ierici  <b>(E)</b> ● - nosaka ieteicamos priek metus glabã anai krãjumã</p>	<p><b>Veicot uzstãdi ãnu, lûdzam pierakstït attiecïgo informãciju izmanto anai turpmãk.</b></p> <p>Modeïa Nr. - _____</p> <p>Sçrijas Nr. - _____</p> <p>Ma ïnas opcijas - _____</p> <p>Pãrdo ãnas pãrst. - _____</p> <p>Pãrdo ãnas pãrst. tãlr. Nr. - _____</p> <p>Klienta numurs - _____</p> <p>Uzstãdi ãnas datums - _____</p>
-----------	--	--

<b>NL</b>	<p><b>HOE ONDERDELEN TE BESTELLEN - Zie schema hierboven.</b></p> <p>Gebruik alleen onderdelen die door TENNANT Company zijn geleverd of soortgelijke onderdelen. Onderdelen en voorraden kunnen online, per telefoon, fax of schriftelijk besteld worden.</p> <p>Volg de stappen hieronder om een juiste levering te garanderen.</p> <ol style="list-style-type: none"> <li><b>(A)</b> Bepaal het machinemodel.</li> <li><b>(B)</b> Lees het serienummer van de machine af van het gegevenslabel.</li> <li><b>(C)</b> Zorg dat het juiste serienummer wordt gebruikt uit de onderdelenlijst.</li> <li>Bepaal het artikelnummer en het aantal. Bestel niet aan de hand van pagina's of referentienummers</li> <li>Geef uw naam, bedrijfsnaam, klantnummer, factuur- en leveringsadres, telefoonnummer en bestelnummer op.</li> <li>Geef gedetailleerde leveringsinstructies op.</li> </ol> <hr/> <p><b>(D)</b> ▽ - geeft een eenheid aan          ▲ - geeft de onderdelen van de eenheid aan  <b>(E)</b> ● - geeft een item aan waarvan wij adviseren dat u dit op voorraad hebt</p>	<p><b>Vul tijdens installatie de onderstaande gegevens in voor eventueel toekomstig gebruik.</b></p> <p>Modelnr. - _____</p> <p>Serienr. - _____</p> <p>Machine-opties - _____</p> <p>Verkoopvert. - _____</p> <p>Telnr. verkoopvert. - _____</p> <p>Klantnummer - _____</p> <p>Installatiedatum - _____</p>
-----------	--	--

<b>NO</b>	<p><b>HVORDAN BESTILLE DELER - Se diagram over.</b></p> <p>Bruk kun deler levert av TENNANT Company eller ekvivalente deler. Deler og forsyninger kan bestilles online, per telefon, per faks eller per post.</p> <p>Følg trinnene under for å sikre rask levering.</p> <ol style="list-style-type: none"> <li><b>(A)</b> Angi maskinmodellen.</li> <li><b>(B)</b> Angi maskinens serienummer fra typeskiltet.</li> <li><b>(C)</b> Forsikre deg om at korrekt serienummer brukes fra delelisten.</li> <li>Angi delenummer og antall. Bestill ikke ut fra side- eller referansenumre.</li> <li>Angi ditt navn, firmanavn, kunde-ID-nummer, fakturerings- og forsendelsesadresse, telefonnummer og innkjøpsordrenummer.</li> <li>Angi detaljerte forsendelsesinstruksjoner.</li> </ol> <hr/> <p><b>(D)</b> ▽ - angir en delegruppe  <b>(E)</b> ▲ - angir deler inkludert i en delegruppe  <b>(F)</b> ● - angir hvilke lagervarer man bør ha</p>	<p><b>Fyll ut ved installasjonstidspunkt for fremtidig bruk.</b></p> <p>Modellnr. - _____</p> <p>Serienr. - _____</p> <p>Maskinens tillegg - _____</p> <p>Salgsrep. - _____</p> <p>Salgsrep. telefonnr. - _____</p> <p>Kunde-ID-nummer - _____</p> <p>Installasjonsdato - _____</p>
-----------	---	---

<b>PL</b>	<p><b>JAK ZAMAWIAĆ CZĘŚCI - patrz schemat powyżej.</b></p> <p>Należy używać wyłącznie części dostarczanych przez firmę TENNANT Company lub równoważnych. Części i dostawy mogą być zamawiane online, przez telefon, faksem lub pocztą.</p> <p>Aby zapewnić szybką dostawę, należy przestrzegać następujących wskazówek.</p> <ol style="list-style-type: none"> <li><b>(A)</b> Określić model maszyny.</li> <li><b>(B)</b> Określić numer seryjny maszyny znajdujący się na tabliczce znamionowej.</li> <li><b>(C)</b> Odszukać ten numer seryjny w wykazie części.</li> <li>Określić numer części i ilość. Nie zamawiać na podstawie numeru strony lub liczby porządkowej wykazu.</li> <li>Podać swoje nazwisko, nazwę firmy, numer identyfikacyjny klienta, adres dostawy i dostarczenia rachunku, numer telefonu i numer zamówienia zakupu.</li> <li>Podać dokładne instrukcje dotyczące dostawy.</li> </ol> <hr/> <p><b>(D)</b> ▽ - oznacza zespół  <b>(E)</b> ▲ - oznacza część w zespole  <b>(F)</b> ● - oznacza zalecany zapas części zamiennych</p>	<p><b>Prosimy wpisać datę instalacji do późniejszego wykorzystania.</b></p> <p>Nr modelu - _____</p> <p>Nr seryjny - _____</p> <p>Opcje maszyny - _____</p> <p>Przedst. sprzedaży - _____</p> <p>Nr tel. przedst. sprzed. - _____</p> <p>Nr ident. klienta - _____</p> <p>Data instalacji - _____</p>
-----------	--	---

<b>PT</b>	<p><b>COMO ENCOMENDAR PEÇAS - Consulte o diagrama acima.</b></p> <p>Utilize apenas peças fornecidas pela TENNANT Company ou equivalentes. As peças e consumíveis podem ser encomendados online, por telefone, fax ou correio.</p> <p>Siga os passos abaixo para garantir uma entrega rápida.</p> <ol style="list-style-type: none"> <li><b>(A)</b> Identifique o modelo da máquina.</li> <li><b>(B)</b> Identifique o número de série da máquina que se encontra na etiqueta de dados.</li> <li><b>(C)</b> Certifique-se de que usa o número de série correcto da lista de peças.</li> <li>Identifique o número de produto e a quantidade. Não encomende através de números de página ou de referência.</li> <li>Forneça o seu nome, o nome da empresa, o número de ID do cliente, os endereços de facturação e entrega, o número de telefone e o número da nota de encomenda.</li> <li>Forneça instruções de entrega detalhadas.</li> </ol> <hr/> <p><b>(D)</b> ▽ - identifica uma unidade  <b>(E)</b> ▲ - identifica peças incluídas numa unidade  <b>(F)</b> ● - identifica um artigo de stock recomendado</p>	<p><b>Preencha na altura da instalação para futura referência.</b></p> <p>Modelo nº - _____</p> <p>Nº de série - _____</p> <p>Opcões da máquina - _____</p> <p>Vendedor - _____</p> <p>Telefone do vendedor - _____</p> <p>Número de ID do cliente - _____</p> <p>Data de instalação - _____</p>
-----------	---	--

<b>RU</b>	<p><b>КАК ЗАКАЗАТЬ ЗАПЧАСТИ - См. схему ниже.</b></p> <p>Используйте только запчасти, поставляемые компанией TENNANT или их аналоги. Запасные части и расходные материалы можно заказать в режиме онлайн, телефоном, факсом или электронной почтой.</p> <p>Для своевременной доставки следуйте описанным ниже инструкциям.</p> <ol style="list-style-type: none"> <li><b>(A)</b> Укажите модель машины.</li> <li><b>(B)</b> Укажите серийный номер машины, обозначенный на табличке технических данных.</li> <li><b>(C)</b> Удостоверьтесь, что надлежащий серийный номер перечислен в списке запчастей.</li> <li>Укажите номер детали и нужное количество. Не используйте номера страниц или ссылок.</li> <li>Укажите свое имя, название компании, идентификационный номер покупателя, расчетный адрес и адрес доставки, телефонный номер и номер заказа на покупку.</li> <li>Укажите подробные сведения о доставке.</li> </ol> <hr/> <p><b>(D)</b> ▽ - означает узел  <b>(E)</b> ▲ - обозначает деталь узла  <b>(F)</b> ● - обозначает рекомендуемое складское наименование</p>	<p><b>Во время установки заполните, пожалуйста, эти сведения для того, чтобы ссылаться в дальнейшем.</b></p> <p>Модель Э - _____</p> <p>Серийный Э - _____</p> <p>Опции машины - _____</p> <p>Торговый представитель - _____</p> <p>Телефон торгового представителя - _____</p> <p>Идент. номер покупателя - _____</p> <p>Дата установки - _____</p>
-----------	---	--

<b>SE</b>	<p><b>BESTÄLLNING AV RESERVDELAR - Se ovanstående schema.</b></p> <p>Använd endast delar från Tennant Company eller likvärdiga. Delar och material kan beställas online, telefoniskt, per fax eller post.</p> <p>Följ nedanstående steg för en snabb leverans.</p> <ol style="list-style-type: none"> <li><b>(A)</b> Identifiera maskinens modell.</li> <li><b>(B)</b> Identifiera maskinens serienummer på typskylten.</li> <li><b>(C)</b> Kontrollera att rätt serienummer används från dellistan.</li> <li>Identifiera artikelnumret och mängden. Beställ inte med hjälp av sido- eller referensnummer.</li> <li>Uppge ditt namn, företagets namn, kundens ID-nummer, faktura- och leveransadress, telefonnummer och ordernumret vid inköp.</li> <li>Ge detaljerade transportanvisningar.</li> </ol> <hr/> <p><b>(D)</b> ▽ - identifierar en modul ▲ - identifierar delar som ingår i en modul <b>(E)</b> ● - identifierar en rekommenderad lagerartikel</p>	<p><b>Fyll i vid installation och spar för framtida bruk.</b></p> <p>Modellnr. - _____</p> <p>Serienr. - _____</p> <p>Tilvalsutrustning - _____</p> <p>Försäljare - _____</p> <p>Försäljarens tel.nr. - _____</p> <p>Kundnummer - _____</p> <p>Installationsdatum - _____</p>
-----------	---	---

<b>SK</b>	<p><b>POSTUP PRI OBJEDNÁVANÍ ČASTÍ - Pozri vyššie uvedený diagram.</b></p> <p>Využívajte výhradne dielce dodané spoločnosťou TENNANT, alebo ich ekvivalenty. Dielce a položky je možné objednať online, telefonicky, faxom, alebo poštou.</p> <p>Na zabezpečenie promptného doručenia sa riadte nasledovnými krokmi.</p> <ol style="list-style-type: none"> <li><b>(A)</b> Identifikujte model stroja.</li> <li><b>(B)</b> Z etikety s údajmi identifikujte sériové číslo stroja.</li> <li><b>(C)</b> Ubezpečte sa, že ste zadali správne sériové číslo zo zoznamu dielcov.</li> <li>Identifikujte číslo dielu a množstvo. Neobjednávajte pomocou čísel strán, alebo referenčných čísel.</li> <li>Zadajte Vaše meno, meno spoločnosti, ID číslo zákazníka, fakturačnú a prepravnú adresu, telefónne číslo a objednávacie číslo dielu.</li> <li>Uvedte podrobné prepravné pokyny.</li> </ol> <hr/> <p><b>(D)</b> ▽ - identifikuje sadu ▲ - identifikuje časti sady <b>(E)</b> ● - identifikuje odporúčanú skladovú položku</p>	<p><b>Vyplňte prosím pri inštalácii pre prípad potreby v budúcnosti.</b></p> <p>č. modelu - _____</p> <p>Sériové č. - _____</p> <p>Zvláštne príslušenstvo stroja - _____</p> <p>Obchodné zastúpenie - _____</p> <p>Obch. zastúpenie tel. č. - _____</p> <p>ID č. zákazníka - _____</p> <p>Dátum inštalácie - _____</p>
-----------	---	--

<b>SL</b>	<p><b>NAROČANJE NADOMESTNIH DELOV - glejte zgornjo sliko.</b></p> <p>Uporabljajte samo originalne nadomestne dele Tennant ali enakovredne dele. Dele in potrošni material lahko naročite prek spleta, po telefonu, faksu ali pošti.</p> <p>Za zagotovitev čimbolj hitre dostave sledite spodnjim navodilom.</p> <ol style="list-style-type: none"> <li><b>(A)</b> Ugotovite model stroja.</li> <li><b>(B)</b> Na ploščici s podatki poiščite serijsko številko stroja.</li> <li><b>(C)</b> Poskrbite, da na seznamu nadomestnih delov poiščete pravilno serijsko številko.</li> <li>Poiščite številko dela in potrebno količino. Pri naročilih ne navajajte strani ali referenčne številke.</li> <li>Navedite svoje ime, ime podjetja, ID številko stranke, naslova za dostavo in izdajo računa, telefonsko številko in številko naročila.</li> <li>Navedite podrobna navodila za dostavo.</li> </ol> <hr/> <p><b>(D)</b> ▽ - označuje sklop ▲ - označuje dele sklopa <b>(E)</b> ● - označuje del, za katerega je priporočeno, da ga imate v zalogi</p>	<p><b>Prosimo, da ob vgradnji izpolnite te podatke, da vam bodo v prihodnje na voljo.</b></p> <p>Št. modela - _____</p> <p>Serijska številka - _____</p> <p>Dodatna oprema stroja - _____</p> <p>Prodajni predstavnik - _____</p> <p>Telefonska št. prodajnega predstavnika - _____</p> <p>Številka stranke - _____</p> <p>Datum vgradnje - _____</p>
-----------	---	---

<b>TR</b>	<p><b>PARÇALARIN ŞİPARİŞ EDİLMESİ - Yukarıdaki şemaya bakın.</b></p> <p>Yalnızca TENNANT Company'den sağlanan veya eşdeğerde parçalar kullanın. Parça veya sarf malzemeleri çevrimiçi olarak, telefonla, faksla veya postayla sipariş edilebilir.</p> <p>Zamanında teslimatı sağlamak için aşağıdaki adımları izleyin.</p> <ol style="list-style-type: none"> <li><b>(A)</b> Makine modelini belirtin.</li> <li><b>(B)</b> Veri etiketinden makine seri numarasını belirtin.</li> <li><b>(C)</b> Parça listesinden uygun seri numarasının kullanıldığından emin olun.</li> <li>Parça numarasını ve miktarını belirtin. Sayfa veya referans numaralarını kullanarak sipariş vermeyin.</li> <li>Adınızı, şirketinizin adını, müşteri kimlik numaranızı, faturalama ve sevkiyat adreslerini, telefon numarasını ve satın alma siparişi numarasını belirtin.</li> <li>Ayrıntılı sevkiyat talimatlarını belirtin.</li> </ol> <hr/> <p><b>(D)</b> ▽ - bir tertibatı belirtir ▲ - tertibattaki parçaları belirtir <b>(E)</b> ● - önerilen bir stok kalemini belirtir</p>	<p><b>İleri tarihlerde başvurmak için lütfen kurulum sırasında doldurun.</b></p> <p>Model No. - _____</p> <p>Seri No. - _____</p> <p>Makine Seçenekleri - _____</p> <p>Satış Temsilcisi - _____</p> <p>Satış Temsilcisi telefon no. - _____</p> <p>Müşteri Kimlik Numarası - _____</p> <p>Kurulum Tarihi - _____</p>
-----------	---	--

**TABLE OF CONTENTS**

---

HANDLE GROUP, 120V .....	10
HANDLE GROUP, 230V .....	12
FRAME GROUP, 120V .....	14
FRAME GROUP, 230V .....	16
TANKS AND SHROUD GROUP .....	18
TANK COVER GROUP .....	20
VACUUM FAN GROUP .....	22
SOLUTION GROUP .....	24
SCRUB HEAD GROUP, 120V .....	26
SCRUB HEAD GROUP, 230V .....	28
ROLLER TOOL GROUP .....	30
ELECTRICAL DIAGRAM, 120V .....	32
ELECTRICAL DIAGRAM, 230V .....	33

**OPTIONS**

FLOOR TOOL GROUP, 8 in / 203 mm (NEW STYLE) .....	34
FLOOR TOOL GROUP, 8 in / 203 mm (OLD STYLE) .....	36
HAND TOOL GROUP, 4 in / 101 mm (NEW STYLE) .....	38
HAND TOOL GROUP, 4 in / 101 mm (OLD STYLE) .....	39
PUMP-UP CARPET SPRAYER .....	40

HANDLE GROUP, 120V

355070

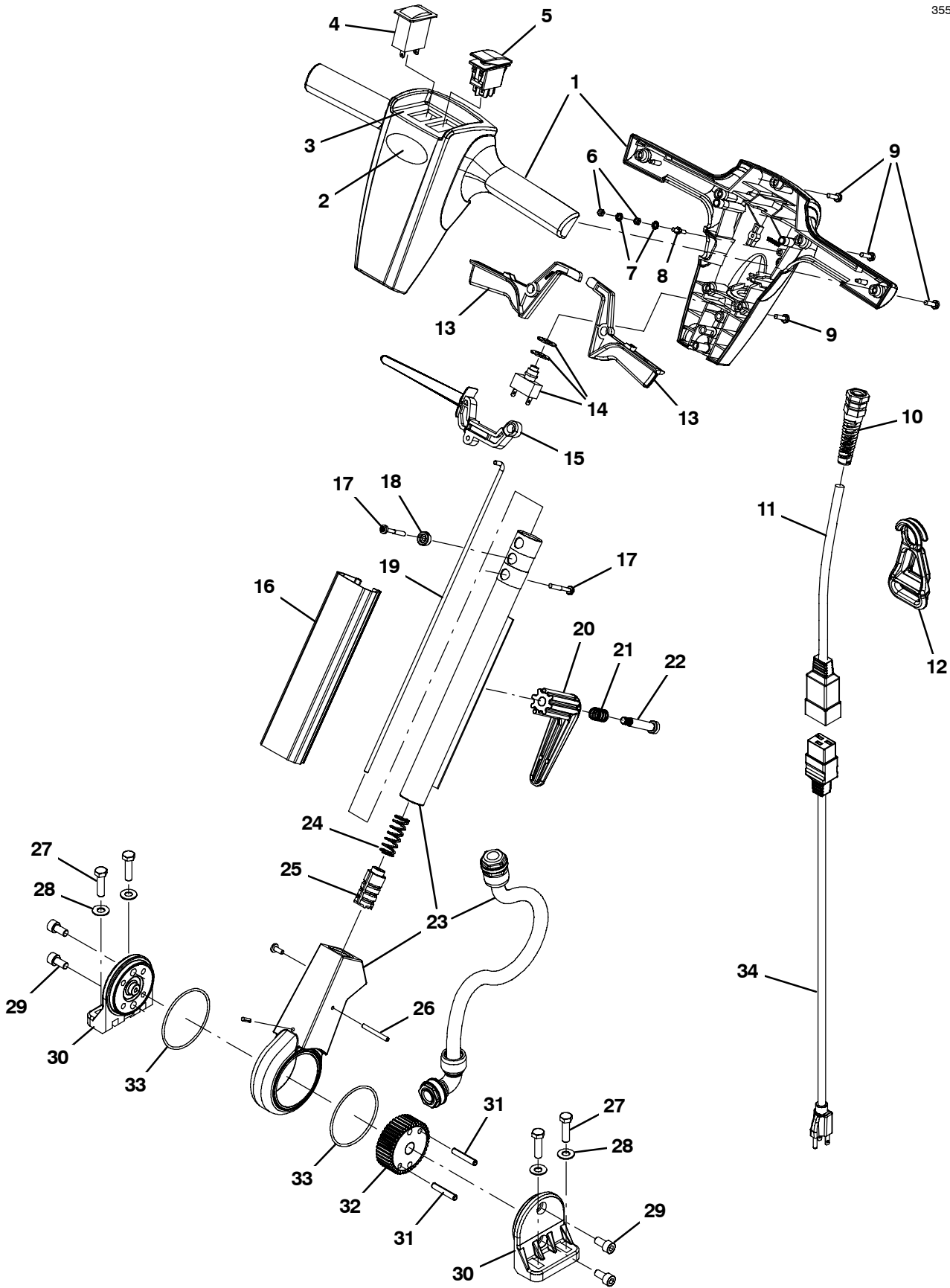

## HANDLE GROUP, 120V

Ref.	Part No.	Serial Number	Description	Qty.
▽	9005507	(60000000-	)● Handle, Tennant R3 [120 Volt]	1
▲▽	1 9004318	(60000000-	)● Cover, Handle Front/Rear Tennant R3 Kit	1
▲▲	2 1042589	(60000000-	) Label, Logo, 02.50l, White [Tennant]	1
▲▲	3 1034592	(60000000-	) Label, Opertnl, Instrmt Panl, Readyspace	1
▲	4 1038375	(60000000-	)● Gauge, Ammeter, 120vac, 5.0a [Rlr Press]	1
▲	5 602919	(60000000-	)● Switch, Rocker, Dpdt, On / On	1
▲	6 42368	(60000000-	) Nut, Hex, Std, M4 X 0.70, 8	2
▲	7 140061	(60000000-	) Washer, Lock, Ext, 08, Pl	2
▲	8 1034952	(60000000-	) Screw, Hex, M4 X 0.7 X 12, Dbl Thrd	1
▲	9 1043573	(60000000-	) Screw, #10-14 X 0.675, Spl[Shcs,Selftap]	7
▲	10 130166	(60000000-	)● Grip, Cord, Strainrelief Pg-11 W/Nut Bk	1
▲	11 1042410	(60000000-	)● Cord, 14ga /3, 16.0l, W/ Receptacle, Yel	1
▲	12 1037147	(60000000-	)● Clip, Cord, Strainrelief, Black	1
▲	13 1033893	(60000000-	)● Lever, Cntrl, Switch [Trex]	2
▲	14 130712	(60000000-	)● Switch, Push, Spst, No	1
▲	15 1034945	(60000000-	) Lever, Adjmt, Handle	1
▲	16 1034181	(60000000-	) Cover, Handle, Tennant [Trex]	1
▲	17 1043572	(60000000-	) Screw, #10-14 X 01.5, Spl[Shcs Selftap]	2
▲	18 1034176	(60000000-	) Bushing, Flng, 5mmb 12mmd 8mml, Pa6	1
▲	19 1034180	(60000000-	) Rod, Release [Trex]	1
▲	20 603104	(60000000-	)● Hook, Cord, Blk [Quick-Release]	1
▲	21 603108	(60000000-	) Spring, Cmpr, Switch	1
▲	22 140239	(60000000-	) Bolt, Shld, .38d X 1.75, .31-18	1
▲	23 1045239	(60000000-	) Tube, Assy, Handle	1
▲	24 1013295	(60000000-	) Spring, Cmpr [2100 Series]	1
▲	25 9006059	(60000000-	) Plunger Kit, Handle	1
▲	26 1034924	(60000000-	) Pin, Roll, 04mmd X 40mml	1
▲	27 1016399	(60000000-	) Screw, Hex, M8 X 1.25 X 30, NI, Ss	4
▲	28 140027	(60000000-	) Washer, Flat, 0.35b 0.75d .04, Ss	4
▲	29 49609	(60000000-	) Screw, Soc, M8 X 1.25 X 16, 12.9	4
▲	30 1000307	(60000000-	) Handle, Pivot, Half	2
▲	31 1034155	(60000000-	) Pin, Roll, 06mmd X 36mml	2
▲	32 1034872	(60000000-	)● Gear, Lock, Handle	1
▲	33 612422	(60000000-	)● Seal, Org, Gear Seat	2
▲	34 1042403	(60000000-	)● Cord, Power, 1.5mm /3 Yel[2x15m 50ft Us]	1

▽ ASSEMBLY

▲ INCLUDED IN ASSEMBLY

● RECOMMENDED STOCK ITEMS

HANDLE GROUP, 230V

355072

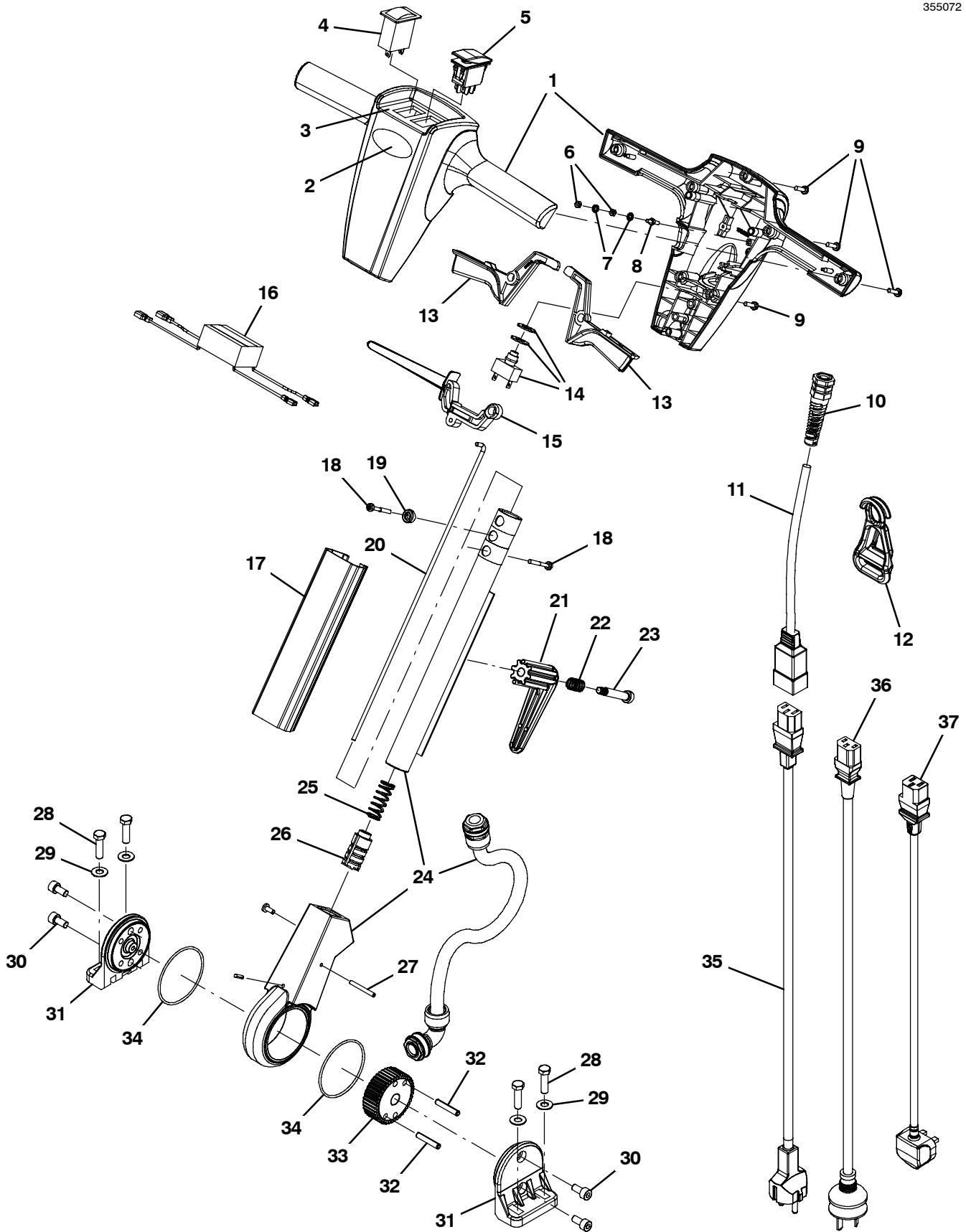

## HANDLE GROUP, 230V

Ref.	Part No.	Serial Number	Description	Qty.
▽	9005510	(60000000-	)● Handle, Tennant R3 [230 Volt]	1
▲▽	1 9004318	(60000000-	)● Cover, Handle Front/Rear Tennant R3 Kit	1
▲▲	2 1042589	(60000000-	) Label, Logo, 02.50l, White [Tennant]	1
▲▲	3 1034592	(60000000-	) Label, Opertnl, Instrmt Panl, Readyspace	1
▲	4 1035742	(60000000-	)● Gauge, Ammeter, 230vac, 2.25a [Rlr Prs]	1
▲	5 602919	(60000000-	)● Switch, Rocker, Dpdt, On / On	1
▲	6 42368	(60000000-	) Nut, Hex, Std, M4 X 0.70, 8	2
▲	7 140061	(60000000-	) Washer, Lock, Ext, 08, Pl	2
▲	8 1034952	(60000000-	) Screw, Hex, M4 X 0.7 X 12, Dbl Thrd	1
▲	9 1043573	(60000000-	) Screw, #10-14 X 0.675, Spl[Shcs,Selftap]	7
▲	10 130166	(60000000-	)● Grip, Cord, Strainrelief Pg-11 W/Nut Bk	1
1040343 ▲	11 <del>1042410</del>	(60000000-	)● Cord, 14ga /3, 16.0l, W/ Receptacle, <del>Yel</del> Blk	1
▲	12 1037147	(60000000-	)● Clip, Cord, Strainrelief, Black	1
▲	13 1033893	(60000000-	) Lever, Cntrl, Switch [Trex]	2
▲	14 130712	(60000000-	)● Switch, Push, Spst, No	1
▲	15 1034945	(60000000-	) Lever, Adjmt, Handle	1
▲	16 1054252	(60000000-	)● Filter, Handle, 250 Vac, 50/60hz, 8amp	1
▲	17 1034181	(60000000-	) Cover, Handle, Tennant [Trex]	1
▲	18 1043572	(60000000-	) Screw, #10-14 X 01.5, Spl[Shcs Selftap]	2
▲	19 1034176	(60000000-	) Bushing, Flng, 5mmb 12mmd 8mml, Pa6	1
▲	20 1034180	(60000000-	) Rod, Release [Trex]	1
▲	21 603104	(60000000-	)● Hook, Cord, Blk [Quick-Release]	1
▲	22 603108	(60000000-	) Spring, Cmpr, Switch	1
▲	23 140239	(60000000-	) Bolt, Shld, .38d X 1.75, .31-18	1
▲	24 1045239	(60000000-	)● Tube, Assy, Handle	1
▲	25 1013295	(60000000-	) Spring, Cmpr [2100 Series]	1
▲	26 9006059	(60000000-	) Plunger Kit, Handle	1
▲	27 1034924	(60000000-	) Pin, Roll, 04mmd X 40mml	1
▲	28 1016399	(60000000-	) Screw, Hex, M8 X 1.25 X 30, NI, Ss	4
▲	29 140027	(60000000-	) Washer, Flat, 0.35b 0.75d .04, Ss	4
▲	30 49609	(60000000-	) Screw, Soc, M8 X 1.25 X 16, 12.9	4
▲	31 1000307	(60000000-	) Handle, Pivot, Half	2
▲	32 1034155	(60000000-	) Pin, Roll, 06mmd X 36mml	2
▲	33 1034872	(60000000-	)● Gear, Lock, Handle	1
▲	34 612422	(60000000-	)● Seal, Org, Gear Seat	2
	35 1035571	(60000000-	)● Cord, Extn, 1.5mm /3 [2x20m, Ce]	1
	36 1036912	(60000000-	)● Cord, Power, 1.5mm /3 Blk [2x15m, Aus]	1
	37 1036891	(60000000-	)● Cord, Power, 1.5mm /3 Blk [2x20m,Uk]	1

▽ ASSEMBLY

▲ INCLUDED IN ASSEMBLY

● RECOMMENDED STOCK ITEMS

FRAME GROUP, 120V

355064

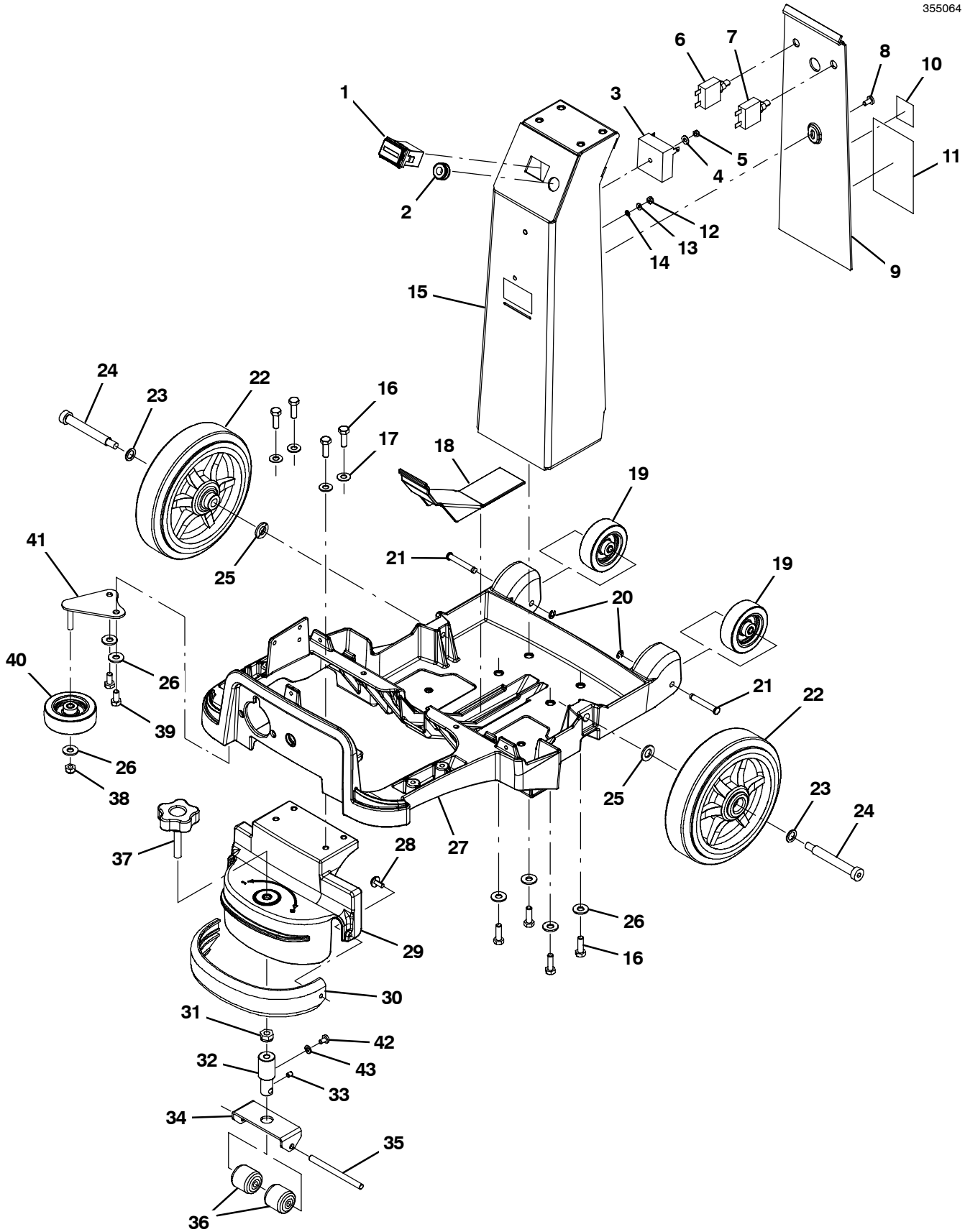

## FRAME GROUP, 120V

Ref.	Part No.	Serial Number	Description	Qty.	
1	1047383	(60000000-	)● Gauge, Hourmeter, 24-277v Ac/Dc, Lcd	1	
2	86726	(60000000-	) Grommet, Rbr, 0.44id, F/0.5h, .19 Matl	1	
3	1032018	(60000000-	)● Module, Timer, 120vac [Trex Readyspace]	1	
4	01683	(60000000-	) Washer, Flat, 10, Ss	1	
5	09739	(60000000-	) Nut, Hex, Lock, M5 X 0.80, NI, Ss	1	
6	383720	(60000000-	)● Circuitbreaker, 05.0a, Resetable	1	
7	383722	(60000000-	)● Circuitbreaker, 15.0a, Resetable	1	
8	74027	(60000000-	) Screw, Pan, Phl, M6 X 1.00 X 12, NI, PI	1	
▽	9	9004275	(60000000-	) Cover Kit, Column , W/ Label [5gal 120v]	1
▲	10	NA	(60000000-	) Label, Safety, 120vac [EtI]	1
▲	11	1039105	(60000000-	) Label,Warning,Ac Scrb/Extr [En/Fr/Es/Jp]	1
	12	1044427	(60000000-	) Nut, Hex, Lock, #8-32, NI, Ss	1
	13	41578	(60000000-	) Washer, Flat, 06, Ss	1
	14	02938	(60000000-	) Washer, Lock, Int, 08, Ss	1
	15	9004274	(60000000-	) Column Kit, Sppt, W/ Label [5 Gal]	1
	16	1015852	(60000000-	) Screw, Hex, M8 X 1.25 X 25, NI, FI, Ss	8
	17	140027	(60000000-	) Washer, Flat, 0.35b 0.75d .04, Ss	4
	18	1031418	(60000000-	) Cover, Frame, Rear [Trex]	1
	19	1014918	(60000000-	)● Wheel, 03.0d 0.88w 0.31b, W/ Bshg, Rbr	2
	20	1035139	(60000000-	) Ring, Retaining, Ext, 0.31d, E-Type	2
	21	1035137	(60000000-	) Pin, Clevis, Grvd 0.31d X 2.00l, Ss	2
	22	1039073	(60000000-	)● Wheel Assy, 8.0d 2.0w 0.5b W/Brg	2
	23	1038770	(60000000-	) Washer, Flat, 0.50b 0.75d 0.06, Ss	2
	24	1033757	(60000000-	) Bolt, Shld, .50 X 3.25, .38-16, Ss	2
	25	33925	(60000000-	) Washer, Flat, M12, Ss	2
	26	01685	(60000000-	) Washer, Flat, 0.38b 0.88d .08, Ss	6
	27	1031527	(60000000-	) Frame (Machined)	1
	28	1019349	(60000000-	) Screw, Trs, M6 X 1.00 X 16, Ss, Sems	2
	29	1051665	(60000000-	) Bracket, Adjustment, Head	1
	30	1036668	(60000000-	) Bumper, Front	1
	31	08714	(60000000-	) Nut, Hex, Lock, M10 X 1.5, NI, Ss	1
	32	1051666	(60000000-	) Adjuster, Roller	1
	33	09162	(60000000-	) Screw, Set, Soc, M6 X 1.00 X 8, NI	1
	34	1035496	(60000000-	) Bracket, Roller	1
	35	1035519	(60000000-	) Bar, Rnd, Stl, 0.31d X 4.09l, 2cham	1
	36	605317	(60000000-	)● Roller, Sqge, 1.35od X 1.48l [Delrin]	2
	37	1036002	(60000000-	)● Knob, Adj, M10 X50 Stud, Blk	1
	38	08713	(60000000-	) Nut, Hex, Lock, M8 X 1.25, NI, Ss	1
	39	49826	(60000000-	) Screw, Hex, M8 X 1.25 X 16, NI, Ss	2
	40	1014918	(60000000-	)● Wheel, 03.0d 0.88w 0.31b, W/ Bshg, Rbr	1
	41	1034805	(60000000-	) Bracket, Bumper Wheel	1
	42	48732	(60000000-	) Screw, Pan, Phl, M6 X 1.00 X 10, Ss	1
	43	140016	(60000000-	) Washer, Lock, Split, 0.25, Ss	1
	N/S	1033926	(60000000-	) Harness, Chassis, Ele [T-Rex Readyspace]	1

▽ ASSEMBLY

▲ INCLUDED IN ASSEMBLY

● RECOMMENDED STOCK ITEMS

N/S = NOT SHOWN

FRAME GROUP, 230V

355065

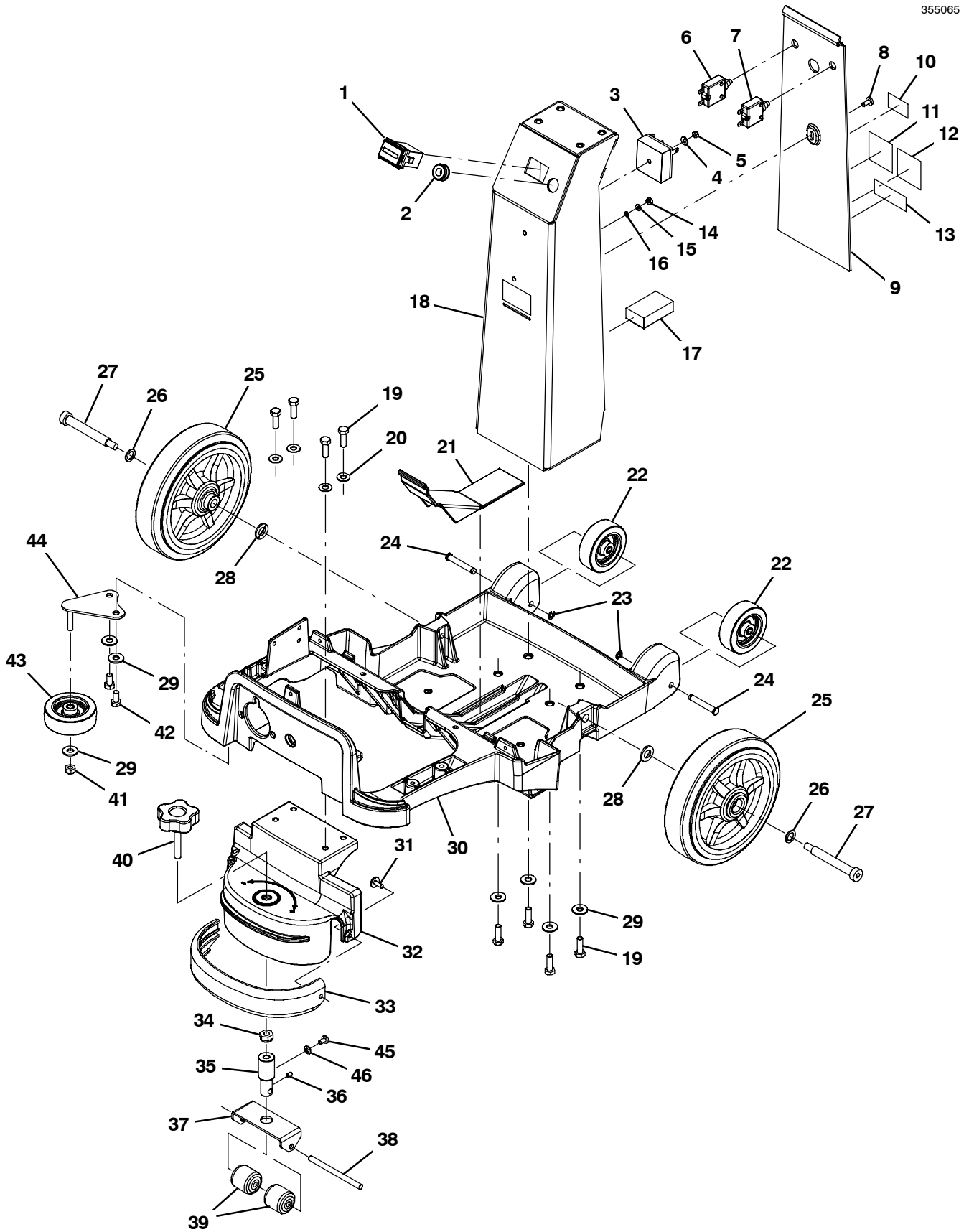

## FRAME GROUP, 230V

Ref.	Part No.	Serial Number	Description	Qty.	
1	1047383	(60000000-	)● Gauge, Hourmeter, 24-277v Ac/Dc, Lcd	1	
2	86726	(60000000-	) Grommet, Rbr, 0.44id, F/0.5h, .19 Matl	1	
3	1032245	(60000000-	)● Module, Timer, 240vac[T-Rex Readyspace]	1	
4	01683	(60000000-	) Washer, Flat, 10, Ss	1	
5	09739	(60000000-	) Nut, Hex, Lock, M5 X 0.80, NI, Ss	1	
6	1037100	(60000000-	)● Circuitbreaker, 2.5 Amp, 230 Volt	1	
7	1037086	(60000000-	)● Circuitbreaker, 7.5 Amp, 230 Volt	1	
8	74027	(60000000-	) Screw, Pan, Phl, M6 X 1.00 X 12, NI, PI	1	
▽	9	9004294	(60000000-	) Column, Cover W/ Labels 5 Gal 230v Kit	1
▲	10	NA	(60000000-	) Label, Safety, 230Vac [Ce, C-Tic]	1
▲	11	1030494	(60000000-	) Label, Hzrd, Flammable Matl, Ce	1
▲	12	1028077	(60000000-	) Label [Read Manual, Iso]	1
▲	13	993852	(60000000-	) Label, Warning [Electrical Hazard]	1
	14	1044427	(60000000-	) Nut, Hex, Lock, #8-32, NI, Ss	1
	15	41578	(60000000-	) Washer, Flat, 06, Ss	1
	16	02938	(60000000-	) Washer, Lock, Int, 08, Ss	1
	17	1043600	(60000000-	)● Filter, Pump, 250 Vac, 3a, 50/60hz	1
	18	9004274	(60000000-	) Column Kit, Sppt, W/ Label [5 Gal]	1
	19	1015852	(60000000-	) Screw, Hex, M8 X 1.25 X 25, NI, FI, Ss	8
	20	140027	(60000000-	) Washer, Flat, 0.35b 0.75d .04, Ss	4
	21	1031418	(60000000-	) Cover, Frame, Rear [Trex]	1
	22	1014918	(60000000-	)● Wheel, 03.0d 0.88w 0.31b, W/ Bshg, Rbr	2
	23	1035139	(60000000-	) Ring, Retaining, Ext, 0.31d, E-Type	2
	24	1035137	(60000000-	) Pin, Clevis, Grvd 0.31d X 2.00l, Ss	2
	25	1039073	(60000000-	)● Wheel Assy, 8.0d 2.0w 0.5b W/Brg	2
	26	1038770	(60000000-	) Washer, Flat, 0.50b 0.75d 0.06, Ss	2
	27	1033757	(60000000-	) Bolt, Shld, .50 X 3.25, .38-16, Ss	2
	28	33925	(60000000-	) Washer, Flat, M12, Ss	2
	29	01685	(60000000-	) Washer, Flat, 0.38b 0.88d .08, Ss	6
	30	1031527	(60000000-	) Frame (Machined)	1
	31	1019349	(60000000-	) Screw, Trs, M6 X 1.00 X 16, Ss, Sems	2
	32	1051665	(60000000-	) Bracket, Adjustment, Head	1
	33	1036668	(60000000-	) Bumper, Front	1
	34	08714	(60000000-	) Nut, Hex, Lock, M10 X 1.5, NI, Ss	1
	35	1051666	(60000000-	) Adjuster, Roller	1
	36	09162	(60000000-	) Screw, Set, Soc, M6 X 1.00 X 8, NI	1
	37	1035496	(60000000-	) Bracket, Roller	1
	38	1035519	(60000000-	) Bar, Rnd, Stl, 0.31d X 4.09l, 2cham	1
	39	605317	(60000000-	)● Roller, Sqge, 1.35od X 1.48l [Delrin]	2
	40	1036002	(60000000-	)● Knob, Adj, M10 X50 Stud, Blk	1
	41	08713	(60000000-	) Nut, Hex, Lock, M8 X 1.25, NI, Ss	1
	42	49826	(60000000-	) Screw, Hex, M8 X 1.25 X 16, NI, Ss	2
	43	1014918	(60000000-	)● Wheel, 03.0d 0.88w 0.31b, W/ Bshg, Rbr	1
	44	1034805	(60000000-	) Bracket, Bumper Wheel	1
	45	48732	(60000000-	) Screw, Pan, Phl, M6 X 1.00 X 10, Ss	1
	46	140016	(60000000-	) Washer, Lock, Split, 0.25, Ss	1
	N/S	1033926	(60000000-	) Harness, Chassis, Ele [T-Rex Readyspace]	1

▽ ASSEMBLY

▲ INCLUDED IN ASSEMBLY

● RECOMMENDED STOCK ITEMS

N/S = NOT SHOWN

TANKS AND SHROUD GROUP

355046

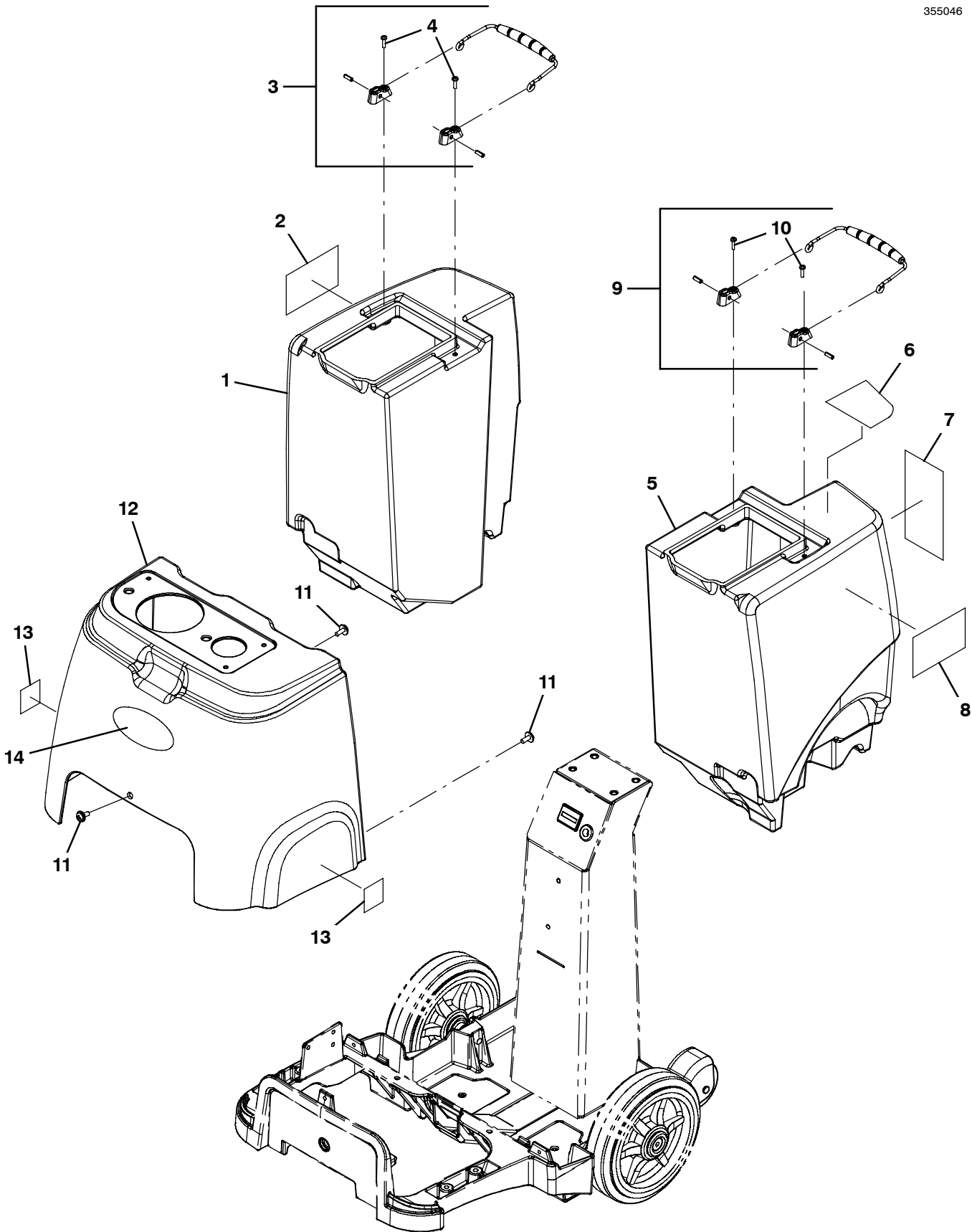

## TANKS AND SHROUD GROUP

	Ref.	Part No.	Serial Number		Description	Qty.
▽	1	9004303	(60000000-	)	Tank, Rec W/ Labels Tennant 5 Gal Kit	1
▲	2	1039086	(60000000-	)	Label, Side [R3 Readyspace]	1
▲▽	3	9004285	(60000000-	)●	Handle, Tank Kit	1
▲▲	4	24265	(60000000-	)	Screw, Pan, Phl, M4 X 0.70 X 16, Ss	2
▽	5	9004305	(60000000-	)	Tank, Sol W/ Labels Tennant 5 Gal Kit	1
▲	6	1038968	(60000000-	)	Label, Soltn, Tank [5.0 Gal]	1
▲	7	1040113	(60000000-	)	Label, Oper, Instr [Readyspace]	1
▲	8	1039086	(60000000-	)	Label, Side [R3 Readyspace]	1
▲▽	9	9004285	(60000000-	)●	Handle, Tank Kit	1
▲▲	10	24265	(60000000-	)	Screw, Pan, Phl, M4 X 0.70 X 16, Ss	2
	11	1019349	(60000000-	)	Screw, Trs, M6 X 1.00 X 16, Ss, Sems	3
▽	12	9004298	(60000000-	)	Shroud, W/ Labels Tennant 5 Gal Kit	1
▲	13	578769	(60000000-	)	Decal, Moving Parts Textless	2
▲	14	1039084	(60000000-	)	Label, Logo, White, Tennant, 5.5"Lg	1

▽ ASSEMBLY

▲ INCLUDED IN ASSEMBLY

● RECOMMENDED STOCK ITEMS

TANK COVER GROUP

355047

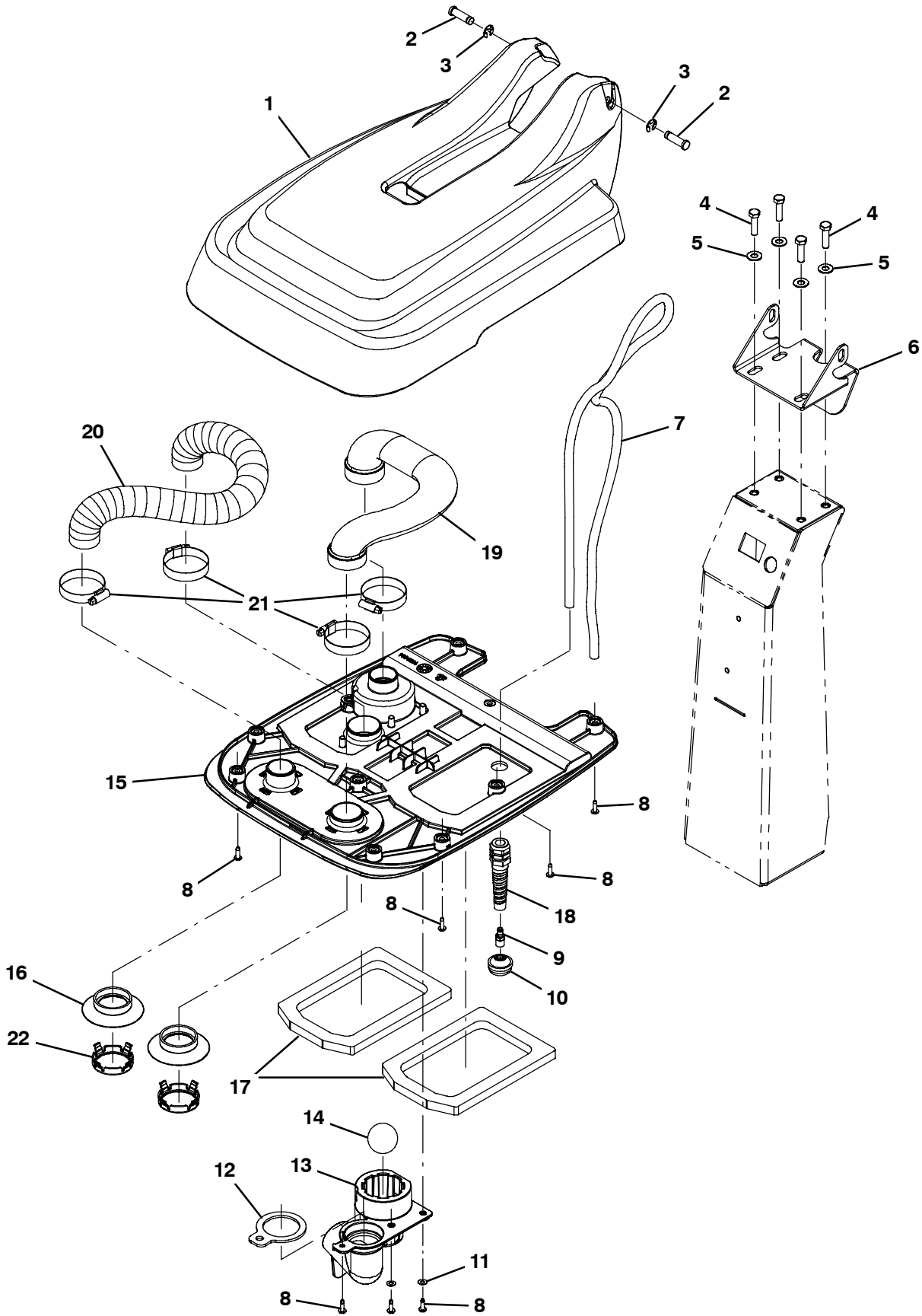

## TANK COVER GROUP

Ref.	Part No.	Serial Number	Description	Qty.
1	1031638	(60000000-	) Cover , Tank, Upper, Tennant [Trex]	1
2	1035358	(60000000-	) Pin, Grvd, 0.375d, 1.25l	2
3	24555	(60000000-	) Ring, Retaining, Ext, 0.38d, [E-Ring]	2
4	1016399	(60000000-	) Screw, Hex, M8 X 1.25 X 30, NI, Ss	4
5	140027	(60000000-	) Washer, Flat, 0.35b 0.75d .04, Ss	4
6	1034346	(60000000-	) Bracket, Pivot, Cover, Mtg	1
7	1036063	(60000000-	) Hose, Soltn, .25 Id, .453 Od, 56.0 L	1
8	140340	(60000000-	) Screw, Pan, Phl, 10-24 X 0.62, Ss[Typ25]	13
9	1042715	(60000000-	) Fitting, Brs, Str, Bm04/Pm02	1
10	1032556	(60000000-	)● Filter, Soltn Tube, 80 Mesh	1
11	140011	(60000000-	) Washer, Flat, 0.21b 0.45d .03, Ss	2
12	1051274	(60000000-	) Gasket, Shield, Float	1
13	1042277	(60000000-	) Shield, Float	1
14	1044370	(60000000-	)● Ball, Float, W/O Cage	1
▽	15	9005924	(60000000-) Cover, Tank, Inner W/ Seals, Kit	1
▲	16	1036090	(60000000-)● Seal, Vacuum [Trex]	2
▲	17	1034801	(60000000-)● Gasket, Tank	2
▲	18	130167	(60000000-)● Strainrelief, Cord, Ele, Pm08, Blk Nyl	1
	19	1035866	(60000000-) Hose, Recvy, Formed [Trex]	1
	20	1037756	(60000000-)● Hose, Vacuum, 1.5od, 18.0l [Wire-Reinf]	1
	21	140308	(60000000-) Clamp, Hose, Wormdrive, 1.31-2.25d, .50w	4
	22	1054345	(60000000-) Clip, Retaining, Seal	2

▽ ASSEMBLY

▲ INCLUDED IN ASSEMBLY

● RECOMMENDED STOCK ITEMS

VACUUM FAN GROUP

355069

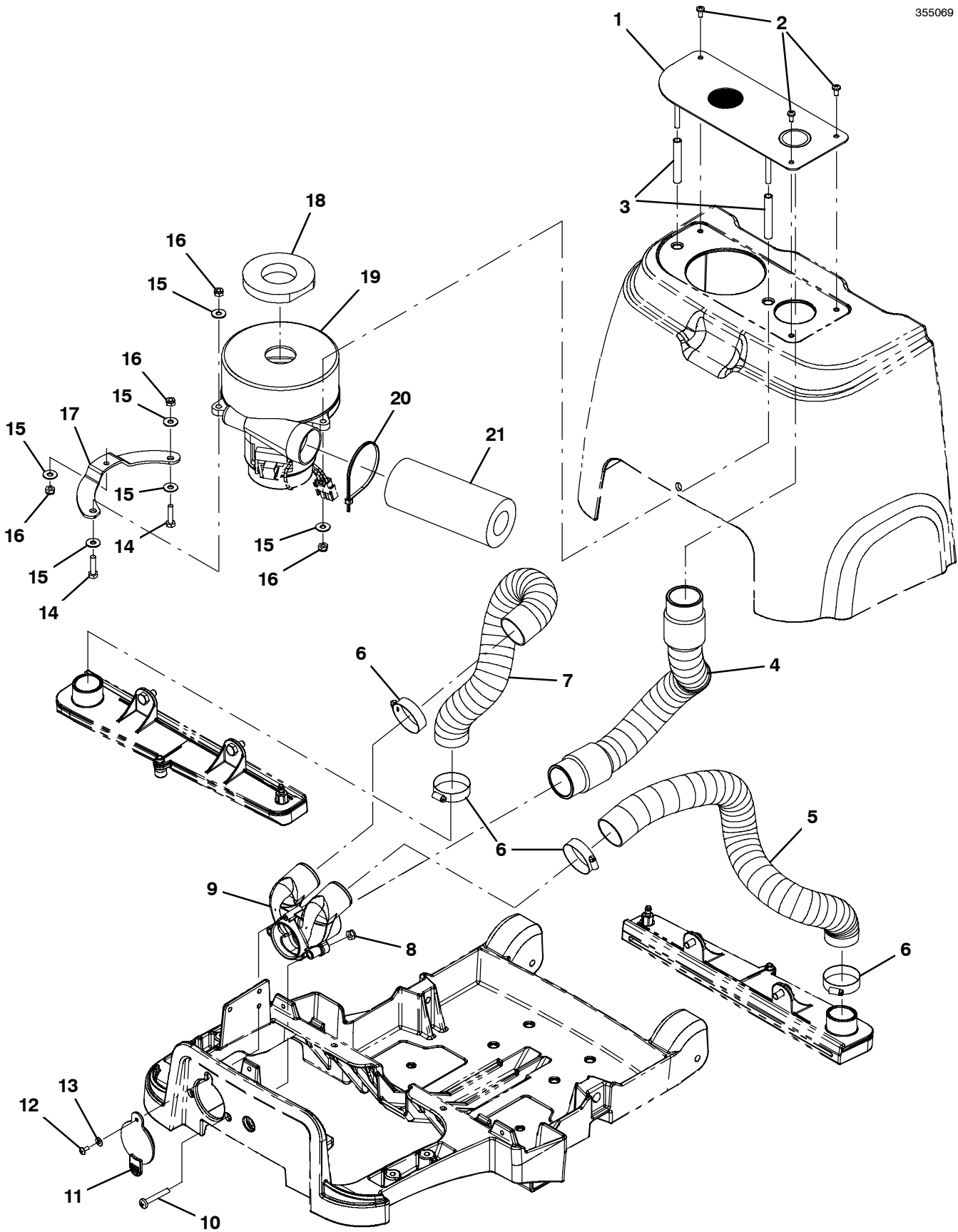

## VACUUM FAN GROUP

Ref.	Part No.	Serial Number	Description	Qty.
1	1031960	(60000000-	) Plate, Mtg, Vacuum	1
2	1026454	(60000000-	) Screw, Pan, Phl, M5 X 0.80 X 10, Ss	3
3	610144	(60000000-	) Spacer, Fan	2
4	1032555	(60000000-	)● Hose, Vacuum, 1.50id X 19.5l, 2cuff, Clr	1
5	1038373	(60000000-	)● Hose, Vacuum, Wir, 38.0id X 490.0l, Clr	1
6	79381	(60000000-	) Clamp, Hose, Wormdrive, 1.25-2.00d, .50w	4
7	1038379	(60000000-	)● Hose, Vacuum, Wir, 38.0id X 335.0l, Clr	1
8	08708	(60000000-	) Nut, Hex, Lock, M6 X 1.00, NI	2
9	1050092	(60000000-	) Manifold, Soltn, Wand [Trex]	1
10	09258	(60000000-	) Screw, Pan, Phl, M6 X 1.00 X 40, 4.8	2
11	607183	(60000000-	)● Seal, Cap, Vacuum Tool [607170]	1
12	140801	(60000000-	) Screw, Trs, Phl, 08-32 X 0.38, Ss	1
13	140011	(60000000-	) Washer, Flat, 0.21b 0.45d .03, Ss	1
14	09007	(60000000-	) Screw, Hex, M6 X 1.00 X 25, Ss	2
15	01684	(60000000-	) Washer, Flat, 0.27b 0.69d .05, Ss	6
16	08708	(60000000-	) Nut, Hex, Lock, M6 X 1.00, NI	4
17	1034069	(60000000-	) Plate, Vac Mounting	1
18	630010	(60000000-	)● Gasket, 12.7mm Th, 43mmid 73mmmod	1
19	1037541	(60000000-	)● Fan, Vacuum, 5.7d, 120 Vac, 2 Stage	1
19	1038018	(60000000-	)● Fan, Vacuum, 5.7d, 240 Vac, 2 Stage	1
20	130773	(60000000-	) Tie, Cable, Nyl, 11.0l, .14w, 3.0 Max. D	1
21	600009	(60000000-	)● Muffler, Exhaust, Vacfan	1

## ● RECOMMENDED STOCK ITEMS

SOLUTION GROUP

355068

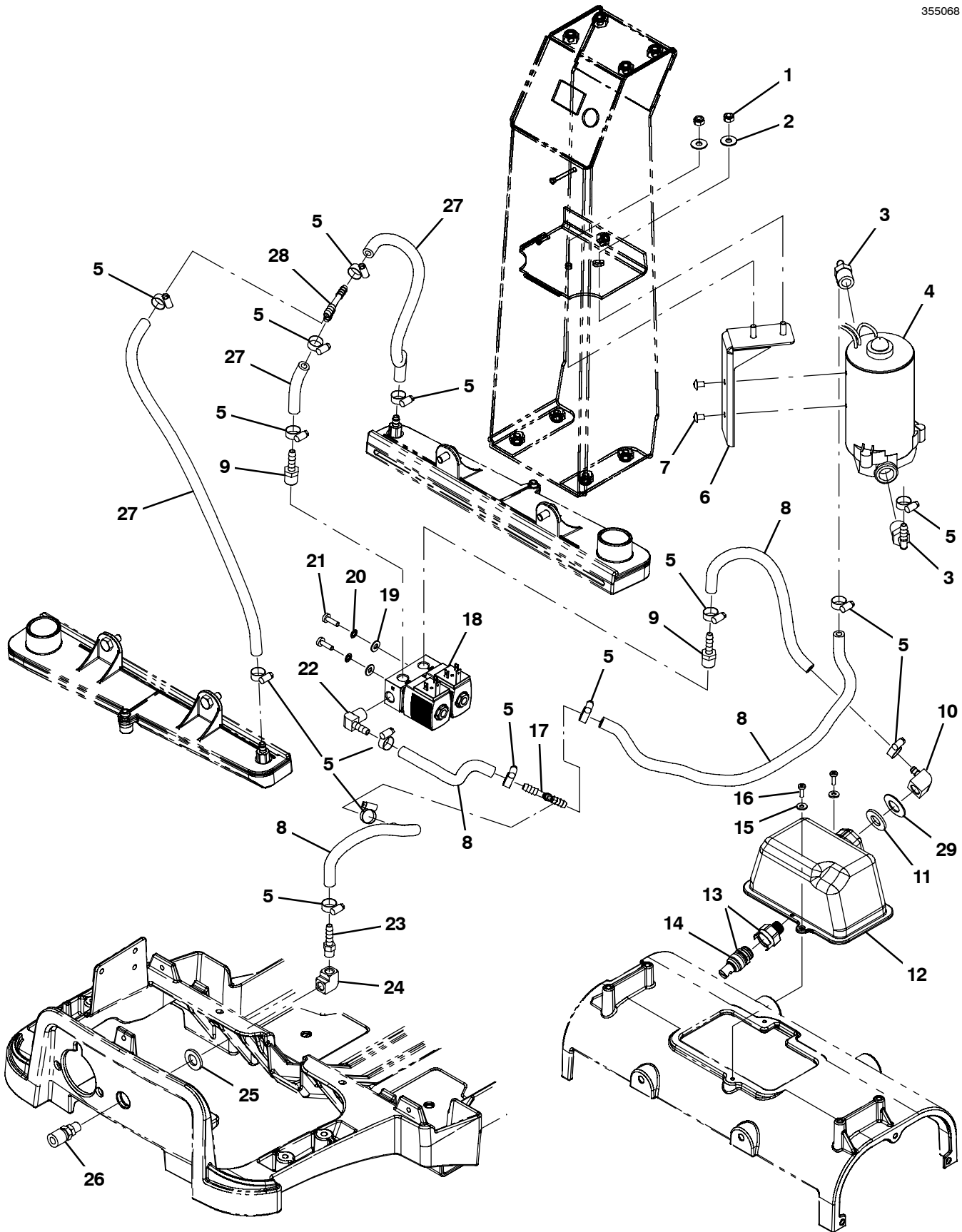

SOLUTION GROUP

Ref.	Part No.	Serial Number	Description	Qty.
1	08712	(60000000-	) Nut, Hex, Lock, M6 X 1.00, NI, Ss	2
2	01684	(60000000-	) Washer, Flat, 0.27b 0.69d .05, Ss	2
3	150417	(60000000-	) Fitting, Plstc, E90, Bm04/Pm06	2
4	1031915	(60000000-	)● Pump, Soltn, Ele, 110vac	1
4	1032241	(60000000-	)● Pump, Ele, Soltn, 230v	1
5	43844	(60000000-	) Clamp, Hose, Wormdrive, 0.25-0.62d, .31w	15
6	1034331	(60000000-	) Bracket, Pump	1
7	140751	(60000000-	) Screw, Hex, 10-32 X 0.50, PI	2
8	606364	(60000000-	) Hose, Pvc, Brd, 0.25id 0.50od 60.0l,Gray (160204)	1
9	150515	(60000000-	) Fitting, Brs, Str, Bm04/Pm04 [Taped]	2
10	1028773	(60000000-	) Fitting, Brs, E90, Bm04/Pf04	1
11	32486	(60000000-	) Washer, Flat, 0.50, Sae	1
12	1033445	(60000000-	) Shroud, Splash, Nozzle [Trex]	1
▽	13	1061033	)● Nozzle Assy, Spray [1/4qjja+Qtka-1]]	1
▲	14	1034685	)● Nozzle, Tip, Spray [Qtka]	1
15	41579	(60000000-	) Washer, Flat, 08, Ss	2
16	579237	(60000000-	) Screw, Pan, Phl, M4 X 0.70 X 12, Ss	2
17	150713	(60000000-	) Fitting, Plstc, Tee, Bm04/Bm04/Bm04	1
18	1037846	(60000000-	)● Manifold, Soltn, 120 Volt	1
18	1038022	(60000000-	)● Manifold, Soltn, 230 Volt	1
19	01683	(60000000-	) Washer, Flat, 10, Ss	2
20	07514	(60000000-	) Washer, Lock, Int, 10, Ss	2
21	140841	(60000000-	) Screw, Pan, Phl, 10-32 X 0.62, Ss	2
22	150418	(60000000-	) Fitting, Brs, E90, Bm04/Pm04	1
23	150525	(60000000-	) Fitting, Brs, Str, Bm04/Pm02	1
24	150402	(60000000-	) Fitting, Brs, E90, Pf02/Pf02	1
25	3148.816	(60000000-	) Washer, Flat, 0.52b 0.88d .06, Stl, PI	1
26	150915	(60000000-	)● Fitting, Brs, Qdc, Pm02, Fem [Ser 5]	1
27	606161	(60000000-	) Hose, Pvc, Brd, 0.25id 0.50od 36.0l,Gray (160204)	1
28	150713	(60000000-	) Fitting, Plstc, Tee, Bm04/Bm04/Bm04	1
29	1035296	(60000000-	) Washer, Flat, Belleville, .567	1

▽ ASSEMBLY

▲ INCLUDED IN ASSEMBLY

● RECOMMENDED STOCK ITEMS

▽ ASSEMBLY

▲ INCLUDED IN ASSEMBLY

SCRUB HEAD GROUP, 120V

355066

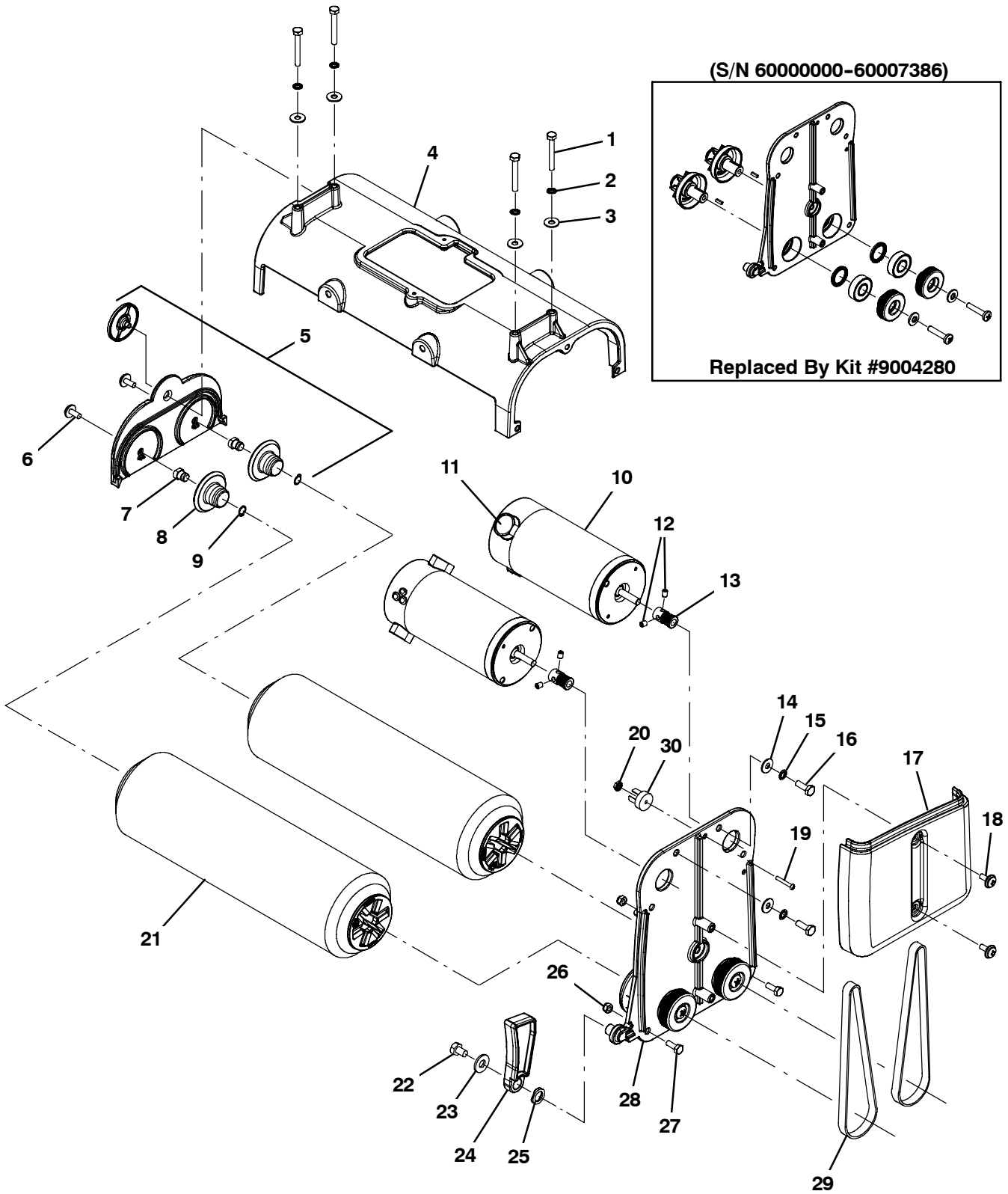

## SCRUB HEAD GROUP, 120V

Ref.	Part No.	Serial Number	Description	Qty.
1	1045325	(60000000-	) Screw, Hex, M6 X 1.00 X 45, Ss	8
2	1027144	(60000000-	) Washer, Lock, Int, M6, Ss	8
3	01684	(60000000-	) Washer, Flat, 0.27b 0.69d .05, Ss	8
4	1054903	(60000000-	) Housing, Brush, Dbl, 40cm	1
▽	5	9007963	(60000000-) Door Kit, Brush, W/ Hdwr	1
▲	6	1019349	(60000000-) Screw, Trs, M6 X 1.00 X 16, Ss, Sems	2
▲	7	1030682	(60000000-) Shaft, Idler Plug	2
▲	8	1030680	(60000000-) Hub, Idler, Brush	2
▲	9	01543	(60000000-) Ring, Retaining, Ext, 0.39d, Basic	2
▽	10	1035298	(60000000-)● Motor, .25hp, 115vdc, 2.1a, 1550 Rpm	2
▲	11	1045465	(60000000-)● Brush, Carbon (Pk=2) Ref Part 1035298	4
	12	09162	(60000000-) Screw, Set, Soc, M6 X 1.00 X 8, NI	4
	13	1030623	(60000000-) Sheave, 07grv, 16.03pd [Ph]	2
	14	01684	(60000000-) Washer, Flat, 0.27b 0.69d .05, Ss	4
	15	07515	(60000000-) Washer, Lock, Int, 0.25, Ss	4
	16	34323	(60000000-) Screw, Hex, .25-20 X 0.75, NI	4
	17	1031169	(60000000-) Cover, Belt, Bl-Gr (Dual Roller)	1
	18	1019349	(60000000-) Screw, Trs, M6 X 1.00 X 16, Ss, Sems	2
	19	140946	(60000000-) Screw, Rnd, Sltd, 06-32 X 1.00, Nyl	1
	20	140534	(60000000-) Nut, Hex, #06-32, Nyl	1
	21	1028953	(60000000-)● Roller Assy, Readyspace	2
	22	386868	(60000000-) Screw, Hex, M8 X 1.25 X 12, Ss	1
	23	07515	(60000000-) Washer, Lock, Int, 0.25, Ss	1
	24	1042443	(60000000-) Support, Kickstand, Blk, Nyl	1
	25	140060	(60000000-) Washer .505x.750x.045 Wave	1
	26	08712	(60000000-) Nut, Hex, Lock, M6 X 1.00, NI, Ss	3
	27	15678	(60000000-) Screw, Hex, M6 X 1.00 X 16, Ss	3
	28	9004280	(60000000-) Bracket, Motor Mount W/ Bearing/Seal Kit	1
	29	9004282	(60000000-)● Belt Kit, W/ Installation Tool [Qty 2]	1
	30	130288	(60000000-)● Rectifier, Bridge, Rnd, 12a 1000volt, Ce	1

▽ ASSEMBLY

▲ INCLUDED IN ASSEMBLY

● RECOMMENDED STOCK ITEMS

SCRUB HEAD GROUP, 230V

355067

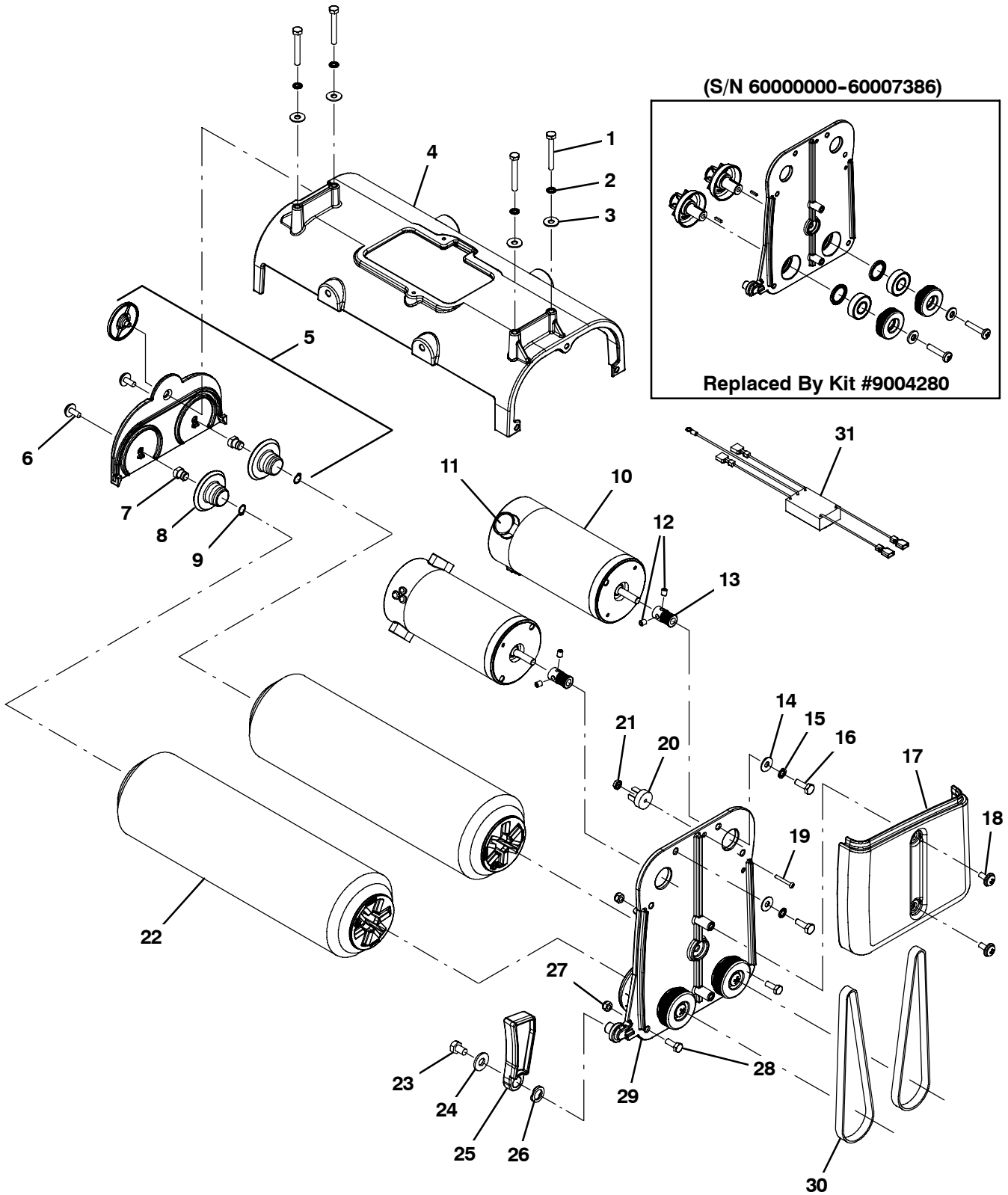

## SCRUB HEAD GROUP, 230V

Ref.	Part No.	Serial Number	Description	Qty.	
1	1045325	(60000000-	) Screw, Hex, M6 X 1.00 X 45, Ss	8	
2	1027144	(60000000-	) Washer, Lock, Int, M6, Ss	8	
3	01684	(60000000-	) Washer, Flat, 0.27b 0.69d .05, Ss	8	
4	1054903	(60000000-	) Housing, Brush, Dbl, 40cm	1	
▽	5	9007963	(60000000-	) Door Kit, Brush, W/ Hdwr	1
▲	6	1019349	(60000000-	) Screw, Trs, M6 X 1.00 X 16, Ss, Sems	2
▲	7	1030682	(60000000-	) Shaft, Idler Plug	2
▲	8	1030680	(60000000-	) Hub, Idler, Brush	2
▲	9	01543	(60000000-	) Ring, Retaining, Ext, 0.39d, Basic	2
▽	10	1036629	(60000000-	)● Motor, .25hp, 230vdc, 1.2a, 1600 Rpm	2
▲	11	1045463	(60000000-	)● Brush, Carbon (Pk=2) Ref Part 1036629	4
	12	09162	(60000000-	) Screw, Set, Soc, M6 X 1.00 X 8, NI	4
	13	1030623	(60000000-	)● Sheave, 07grv, 16.03pd [Ph]	2
	14	01684	(60000000-	) Washer, Flat, 0.27b 0.69d .05, Ss	4
	15	07515	(60000000-	) Washer, Lock, Int, 0.25, Ss	4
	16	34323	(60000000-	) Screw, Hex, .25-20 X 0.75, NI	4
	17	1031169	(60000000-	) Cover, Belt, Bl-Gr (Dual Roller)	1
	18	1019349	(60000000-	) Screw, Trs, M6 X 1.00 X 16, Ss, Sems	2
	19	140946	(60000000-	) Screw, Rnd, Sltd, 06-32 X 1.00, Nyl	1
	20	130288	(60000000-	)● Rectifier, Bridge, Rnd, 12a 1000volt, Ce	1
	21	140534	(60000000-	) Nut, Hex, #06-32, Nyl	1
	22	1028953	(60000000-	)● Roller Assy, Readyspace	2
	23	386868	(60000000-	) Screw, Hex, M8 X 1.25 X 12, Ss	1
	24	07515	(60000000-	) Washer, Lock, Int, 0.25, Ss	1
	25	1042443	(60000000-	) Support, Kickstand, Blk, Nyl	1
	26	140060	(60000000-	) Washer .505x.750x.045 Wave	1
	27	08712	(60000000-	) Nut, Hex, Lock, M6 X 1.00, NI, Ss	3
	28	15678	(60000000-	) Screw, Hex, M6 X 1.00 X 16, Ss	3
	29	9004280	(60000000-	) Bracket, Motor Mount W/ Bearing/Seal Kit	1
	30	9004282	(60000000-	)● Belt Kit, W/ Installation Tool [Qty 2]	1
	31	1036953	(60000000-	)● Filter, Brush, 270 Vdc, 3a	1

▽ ASSEMBLY

▲ INCLUDED IN ASSEMBLY

● RECOMMENDED STOCK ITEMS

ROLLER TOOL GROUP

355077

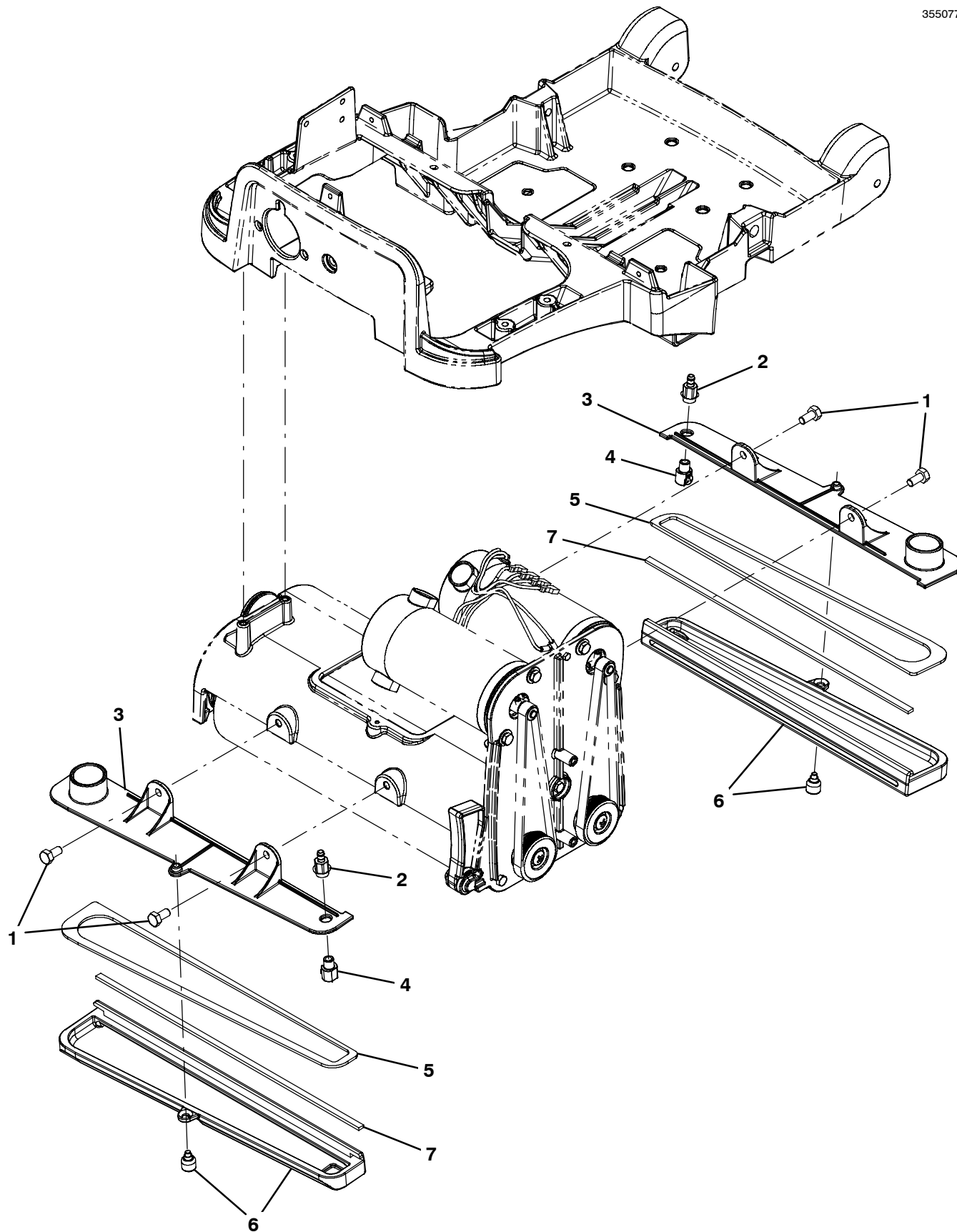

## ROLLER TOOL GROUP

Ref.	Part No.	Serial Number	Description	Qty.
1	49826	(60000000-	) Screw, Hex, M8 X 1.25 X 16, NI, Ss	4
2	1040254	(60000000-	) Fitting, Brs, Str, Bm04/Pf02	2
3	1030390	(60000000-	) Cover, Tool, Str Roll Vacuum, 380mm	2
4	1037380	(60000000-	) Nozzle, Flush, Readyspace	2
5	1034819	(60000000-	)● Gasket, Tool ,Cover	2
6	9004284	(60000000-	) Cover, Tool W/ Hardware Kit	2
7	9006593	(60000000-	)● R3 Foam Gasket Service Kit	1

● RECOMMENDED STOCK ITEMS

ELECTRICAL DIAGRAM, 120V

1046175

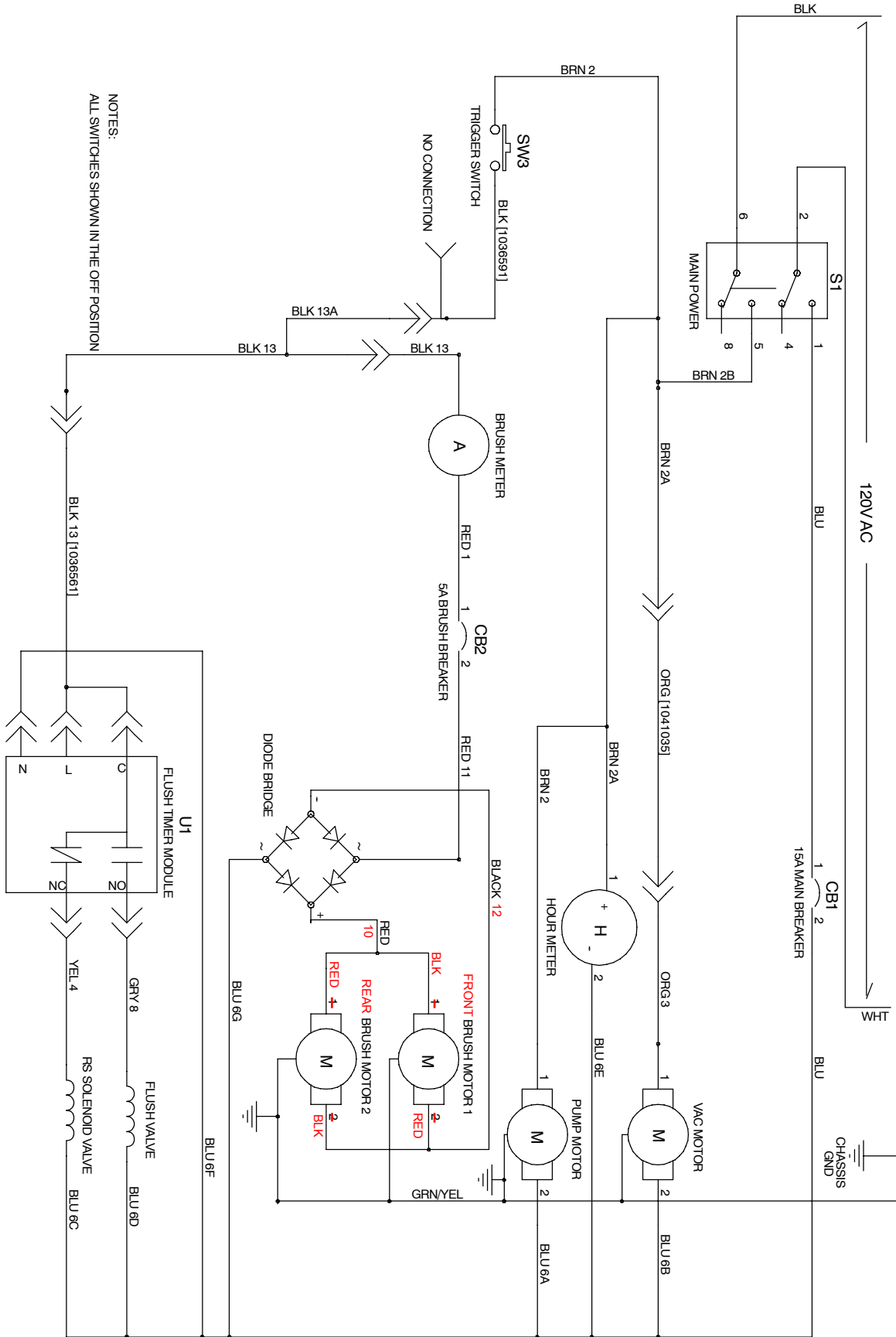

NOTES:  
ALL SWITCHES SHOWN IN THE OFF POSITION

ELECTRICAL DIAGRAM, 230V

1046177

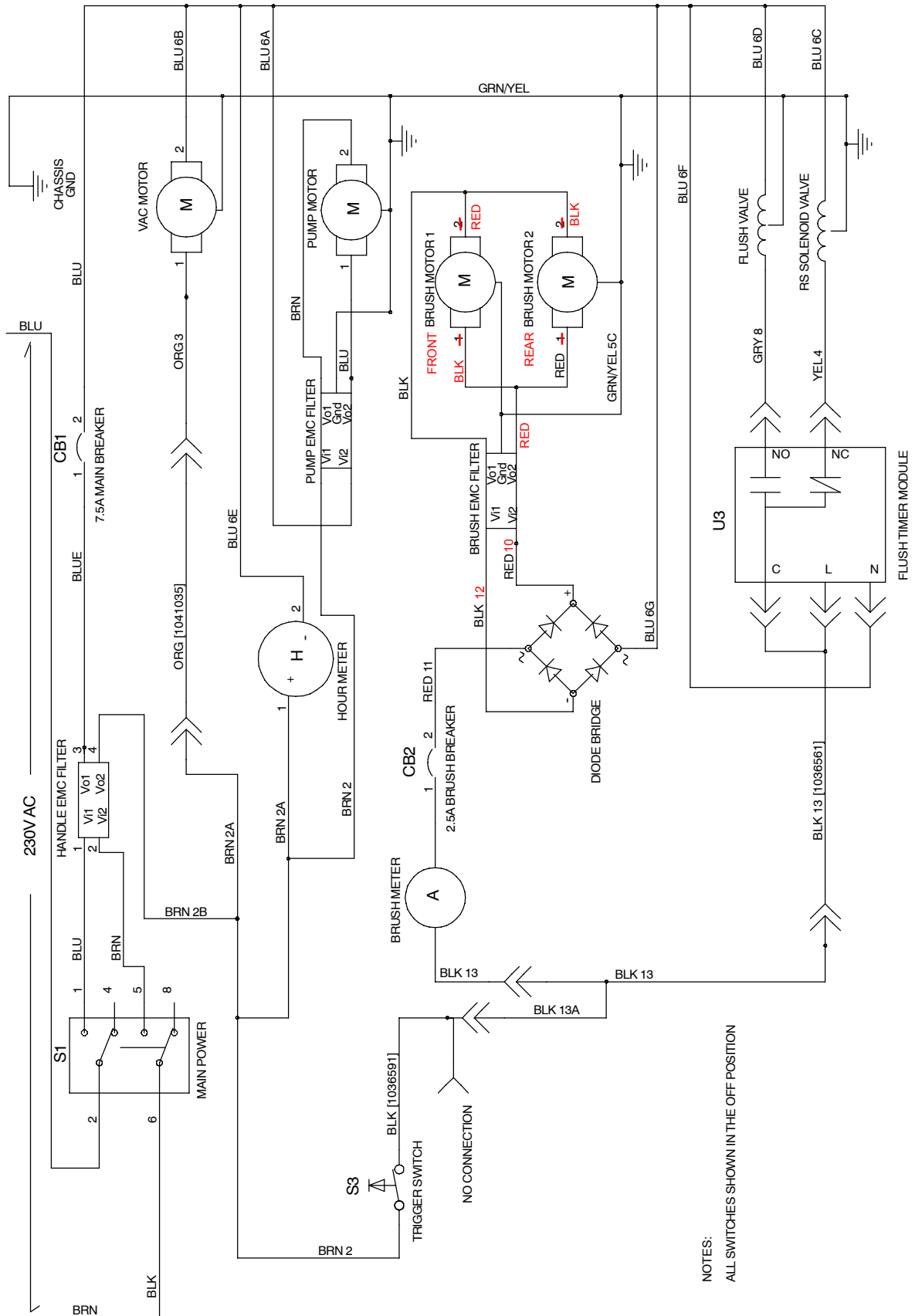

NOTES:  
ALL SWITCHES SHOWN IN THE OFF POSITION

FLOOR TOOL GROUP, 8 in / 203 mm (NEW STYLE)

355116

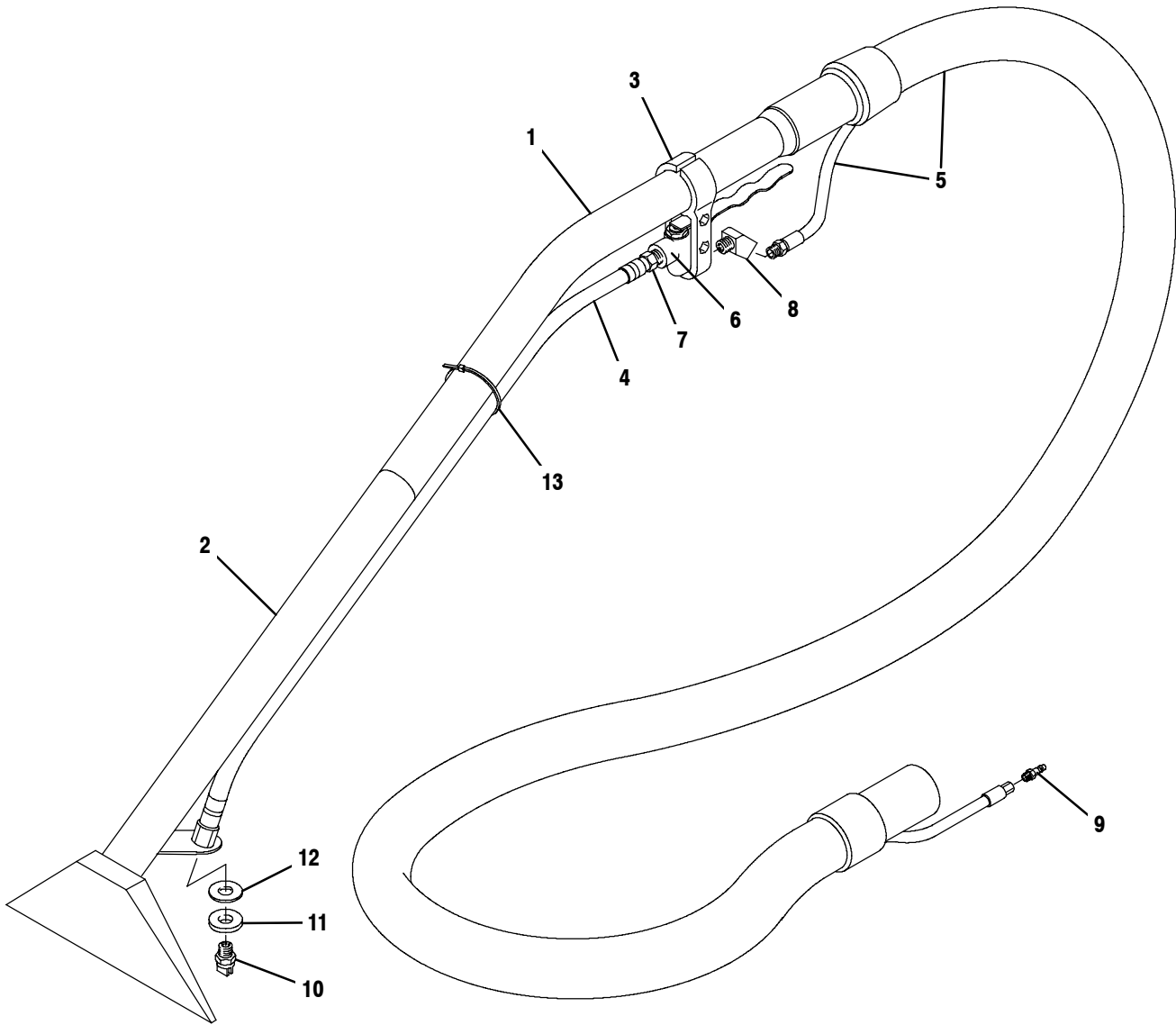

FLOOR TOOL GROUP, 8 in / 203 mm (NEW STYLE)

Ref.	Part No.	Serial Number	Description	Qty.
▽	1058735	(60000000-	)● Tool Assy, Floor, W/ Ss Head	1
▲	1 1058997	(60000000-	) Wand, Tube, Upper, Fr/ 1058735, Replmt	1
▲	2 1058995	(60000000-	) Wand Assy, Lower, Fr/ 1058735, Replmt	1
▲	3 605988	(60000000-	) Vr, Bracket, Hanger, Valve	1
▲	4 1058998	(60000000-	) Hose, Brd, 39.0l, Fr/ 1058735, Replmt	1
▲	5 1059131	(60000000-	)● Hose Assy, 10ft, F/1058735, Replmt	1
▲	6 578064000	(60000000-	)● Valve, Water, Flow Cntrl, W/Lever [Wand]	1
▲	7 150516	(60000000-	) Fitting, Brs, Str, Bm06/Pm04	1
▲	8 150403	(60000000-	) Fitting, Brs, E45, Pf04/Pm04 [Taped]	1
▲	9 150921	(60000000-	)● Fitting, Ss, Qdc, Pm02 [Ser 5]	1
▲	10 1059002	(60000000-	)● Fitting, Jet, Vee, .25npt, Brs	1
▲	11 1058999	(60000000-	) Washer, Flat, Abs, F/ 1058735, Replmt	1
▲	12 140058	(60000000-	) Washer, Flat, 0.54b 0.88d .06, Ss [Wand]	1
▲	13 130041	(60000000-	) Tie, Cable, Nyl, 11.5l .19w	1
	N/S 220040	(60000000-	)● Bag, Hose, Accssry, 24x36[W/Draw String] (Optional)	1

▽ ASSEMBLY

▲ INCLUDED IN ASSEMBLY

● RECOMMENDED STOCK ITEMS

FLOOR TOOL GROUP, 8 in / 203 mm (OLD STYLE) **605976**

355078

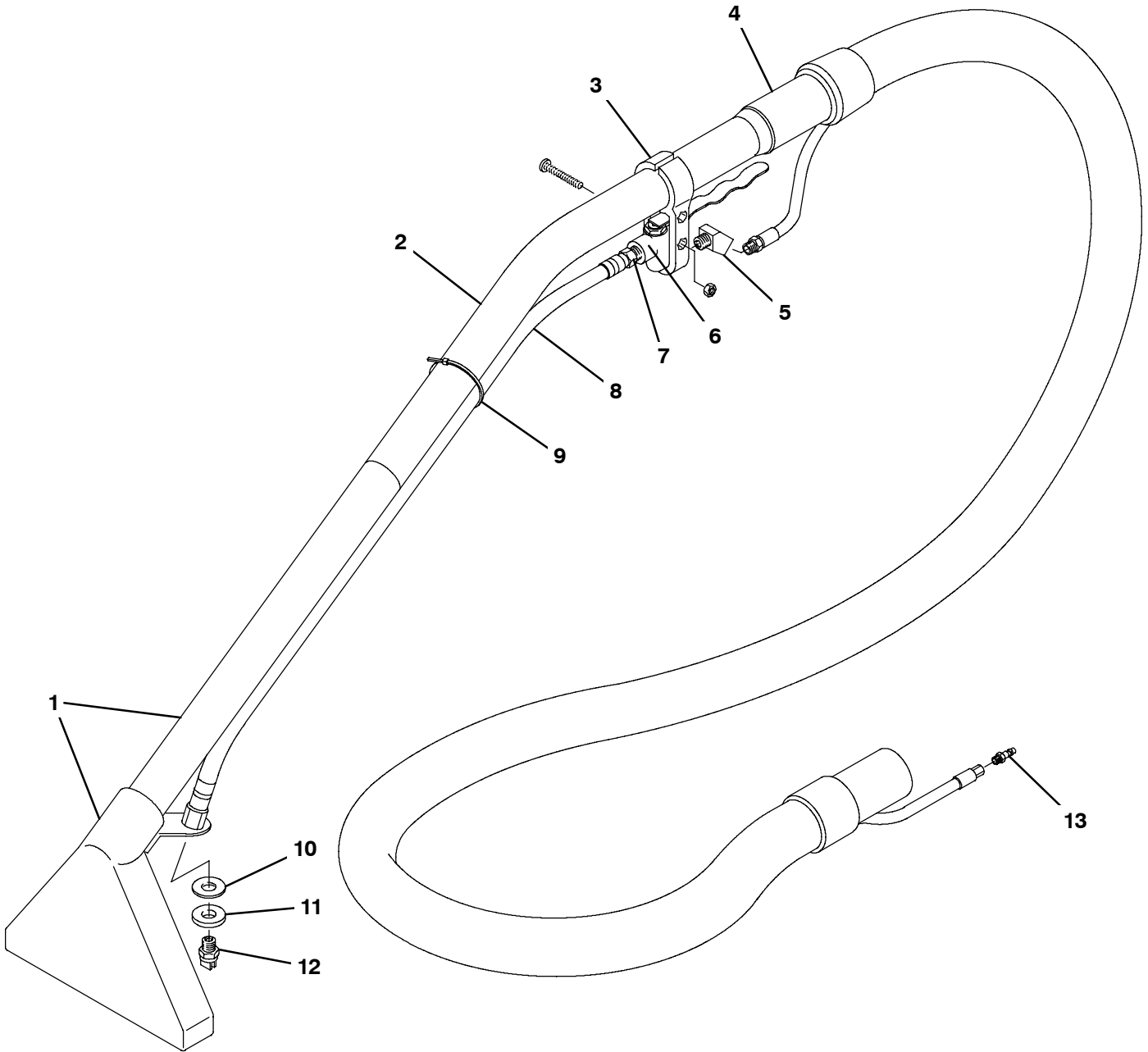

FLOOR TOOL GROUP, 8 in / 203 mm (OLD STYLE) **605976**

Ref.	Part No.	Serial Number	Description	Qty.
▽	N/A	(60000000-	)● Tool, Pickup, Floor, 8.0w, Complt (Rpld By P/N 1058735)	1
▲	1 N/A	(60000000-	) Head Assy, W/ Lower Tube, 8.0inch (Rpld By P/N 1058995)	1
▲	2 N/A	(60000000-	) Wand [Upper Section Only] (Rpld By P/N 1058997)	1
▲	3 605988	(60000000-	) Vr, Bracket, Hanger, Valve	1
▲	4 N/A	(60000000-	)● Hose Assy, 1.25 X 10ft [Hide-A-Hose] (Rpld By P/N 1059131)	1
▲	5 150403	(60000000-	) Fitting, Brs, E45, Pf04/Pm04 [Taped]	1
▲	6 578064000	(60000000-	)● Valve, Cntrl, Water	1
▲	7 150516	(60000000-	) Fitting, Brs, Str, Bm06/Pm05	1
▲	8 N/A	(60000000-	)● Hose Assy, 0.25d [Whip] (Rpld By P/N 1058998)	1
▲	9 130041	(60000000-	) Tie, Cable, Nyl, 11.5l .19w	1
▲	10 140058	(60000000-	) Washer, Flat, 0.54b 0.88d .06, Ss [Wand]	1
▲	11 605990	(60000000-	) Washer, Flat, .53 X 1.1 X .19, Abs	1
▲	12 605989	(60000000-	)● Plstc Vee Jet 8002	1
▲	13 150921	(60000000-	)● Fitting, Ss, Qdc, Pm02 [Ser 5]	1
	N/S 220040	(60000000-	)● Bag, Hose, Accssry, 24x36[W/Draw String] (Optional)	1

▽ ASSEMBLY

▲ INCLUDED IN ASSEMBLY

● RECOMMENDED STOCK ITEMS

HAND TOOL GROUP, 4 in / 101 mm (NEW STYLE)

355117

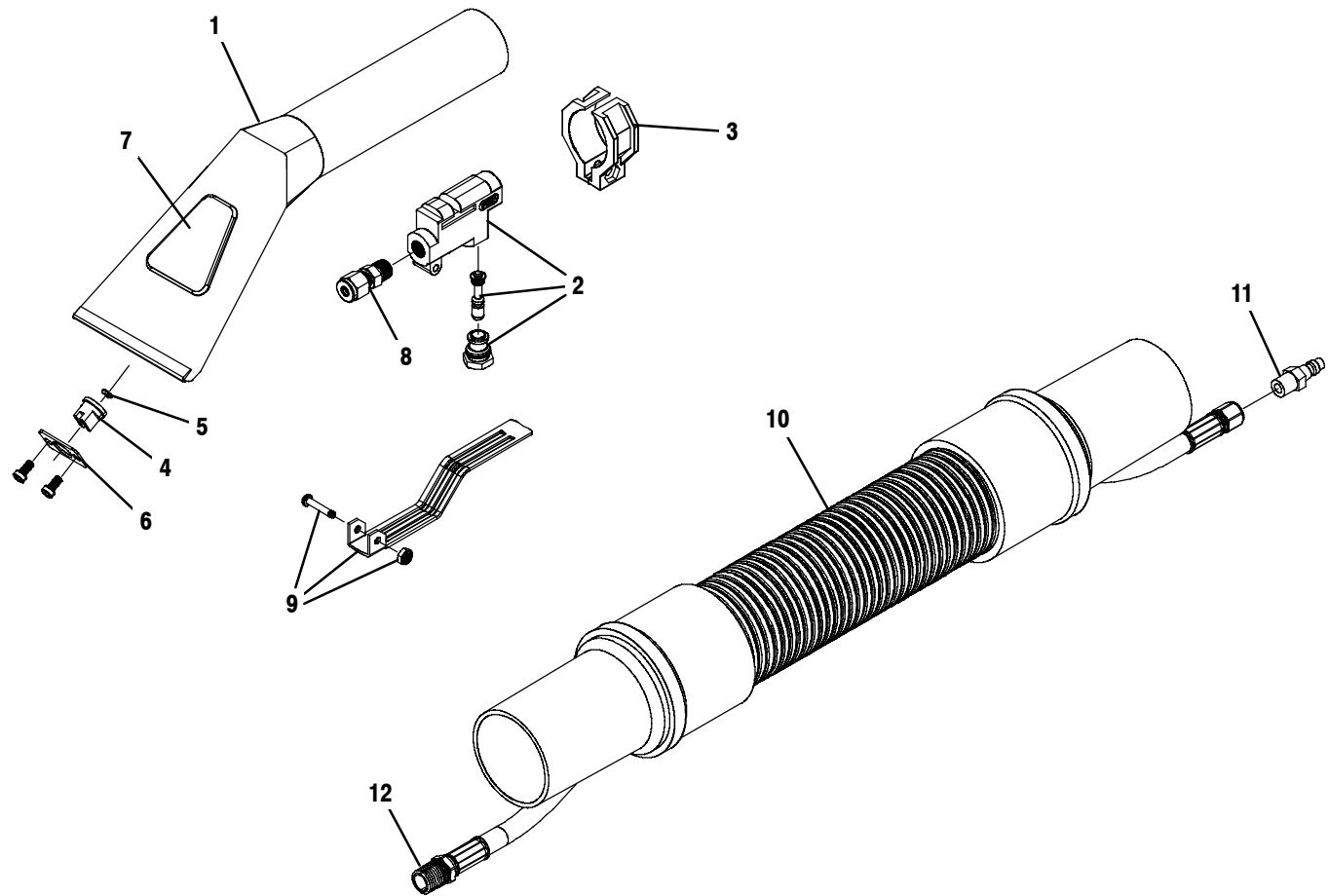

Ref.	Part No.	Serial Number	Description	Qty.
	1058747	(60000000-)	● Tool Assy, Hand, W/ Ss Head & Plstc Wndw	1
▽	1059230	(60000000-)	● Tool Assy, W/Trigger F/1058747, Replmt	1
▲	1 1059003	(60000000-)	● Tool, W/ Wndw, Ss, F/1058747, Replmt	1
▲	2 611807	(60000000-)	) Valve, Tool, Hand [Pmf]	1
▲	3 611812	(60000000-)	) Valve, Hanger [Pmf]	1
▲	4 1059006	(60000000-)	) Fitting, Jet, Tee, Plstc, Fr/ 1058747	1
▲	5 1059005	(60000000-)	● Seal, Org, Fr/ 1058747, Replmt	1
▲	6 611815	(60000000-)	● Retainer, Plate [Pmf]	1
▲	7 1059004	(60000000-)	● Tool, Wndw, Plstc, Fr/ 1058747	1
▲	8 611817	(60000000-)	) Ferrule, Pm02/.18tube	1
▲	9 611818	(60000000-)	) Trigger, Handle Pmf	1
▽	10 1059130	(60000000-)	● Hose Assy, 10ft, F/1058747, Replmt	1
▲	11 150921	(60000000-)	● Fitting, Ss, Qdc, Pm02 [Ser 5]	1
▲	12 150521	(60000000-)	● Fitting, Brs, Str, Bm02/Pf02	1
	N/S 220040	(60000000-)	● Bag, Hose, Accssry, 24x36[W/Draw String] (Optional)	1

▽ ASSEMBLY

▲ INCLUDED IN ASSEMBLY

● RECOMMENDED STOCK ITEMS

HAND TOOL GROUP, 4 in / 101 mm (OLD STYLE) 613396

355079

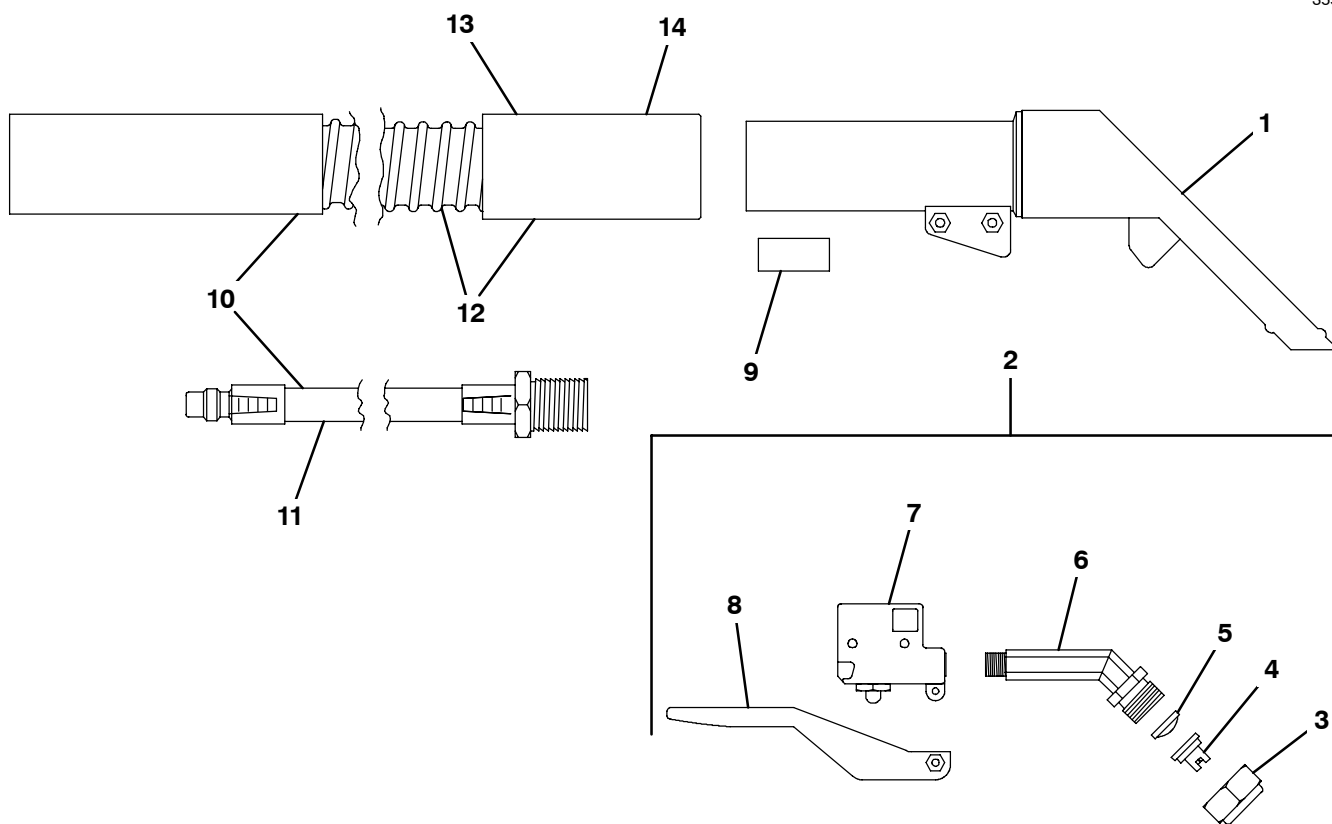

Ref.	Part No.	Serial Number	Description	Qty.	
	N/A	(60000000-	● Tool Assy, Hand, 4.0w, 1.25d Hose[Ser 5] (Rpld By P/N 1058747)	1	
▽	N/A	(60000000-	● Tool, Hand, W/ Trigger Assy (Rpld By P/N 1058747)	1	
▲	1	N/A	(60000000-	● Tool, Hand, W/O Trigger Assy (Rpld By P/N 1058747)	1
▲▽	2	N/A	(60000000-	) Trigger, Hand Tool, Assy (Rpld By P/N 1058747)	1
▲▲	3	608897	(60000000-	● Vr, Nut, Plstc, Spray Tip	1
▲▲	4	608896	(60000000-	● Fitting, Spray, Tip 11003 Blue	1
▲▲	5	608900	(60000000-	● Screen, Tool, Hand	1
▲▲	6	608895	(60000000-	) Fitting, Nozzle, Spray	1
▲▲	7	608894	(60000000-	) Fitting, Valve Body, Hand Tool	1
▲▲	8	608898	(60000000-	) Trigger, Hand Tool	1
	9	608892	(60000000-	) Seal, Hose, Soltn	1
▽	10	N/A	(60000000-	● Hose, Vacuum, 1.25id X 104.0l, 2cuff (Rpld By P/N 1058747)	1
▲	11	N/A	(60000000-	● Hose, Soltn, Hand Tool (Rpld By P/N 1058747)	1
▲▽	12	N/A	(60000000-	● Hose, Vacuum, 1.25id X 104.0l, 1cuff,Blk (Rpld By P/N 1059130)	1
▲▲	13	N/A	(60000000-	● Hose, Vacuum, 1.25id X 088.0l [I-Helix] (Rpld By P/N 1059130)	1
▲▲	14	N/A	(60000000-	● Cuff, Hose, 1.5slip X 1.25thd Blk (Rpld By P/N 1059130)	1
	N/S 220040	(60000000-	● Bag, Hose, Accssry, 24x36[W/Draw String] (Optional)	1	

▽ ASSEMBLY

▲ INCLUDED IN ASSEMBLY

● RECOMMENDED STOCK ITEMS

**PUMP-UP CARPET SPRAYER**

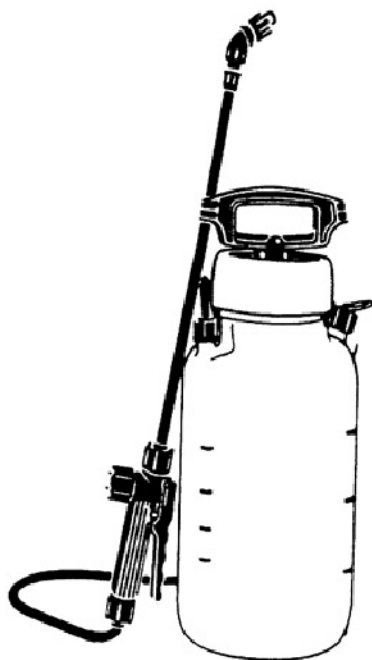

---

<b>Ref.</b>	<b>Part No.</b>	<b>Serial Number</b>	<b>Description</b>	<b>Qty.</b>
	605848	(60000000-	)• Sprayer 2gal Pumpup Hd	1

---

● RECOMMENDED STOCK ITEMS

